

SIDE-POWER
Thruster Systems



Confidence
by Control!



Thrusters
by Side-Power

Confidence by Control

SIDE-POWER





Side-Power by Sleipner Motor

The leading position of Side-Power thrusters is a clear result of focus on the products performance, functionality and reliability.

For many years Side-Power has been the brand that others are trying to copy, but through extensive investments in product development, we have remained ahead of the pack.

Over the last 9 years we have evolved into the Superyacht and commercial sectors with the SP550 thruster and gained the necessary experience to know how to satisfy these markets. One point that perhaps makes us a little different from many of the traditional suppliers to the superyacht and commercial sectors is that while we develop and manufacture really top class products, we are more efficient than most, especially for the actual quality level. This comes from our experience in making thousands of smaller thrusters a year and the need to be cost efficient to be successful in these markets. We focus a lot on investing in the development of our products , not least to make them efficient to manufacture in volumes.

Many of the leading brands of large yachts use our complete hydraulic systems for their models up to 30m today and these products are getting better and better. To further grow in these market sectors, we are now introducing two larger thruster models:

SH1000 & SH1400

The SH1000 delivers 1000kg of thrust in a 20 inch tunnel, while the SH1400 delivers 1400 kg of thrust in a 24 inch tunnel. The two new thrusters is fitted with a bronze Q-prop 5-blade propeller, which is highly energy efficient and very silent.

The SH1000/SH1400 is Type Approved by Det Norske Veritas, and will be delivered in two versions, powered either with by hydraulic or a AC electric motor. The thruster system is controlled by the S-link control system, benefitting from all advantages of a bus-based digital control system.





TOTAL INTEGRATION

The new thrusters in the SH/SAC-series is a part of a total yacht control system. All components in the Side-Power yacht systems are communicating through the S-link CAN-bus based system. This enables the best integration possible of all components available. Every combination of Side-Power components are possible - AC thrusters can be combined with Hydraulic thrusters or hydraulic stabilizers can be integrated with AC/hydraulic thrusters. This is a major advantage not found in competing systems.

The examples shown here are just an indication of the many possible ways to integrate previously separate systems - giving a wide area of benefits both during construction and building of the yacht, and also for the operation and maintenance of the systems.

Additional information about our S-link compatible products are found in our separate product brochures as well as on our web site: www.side-power.com

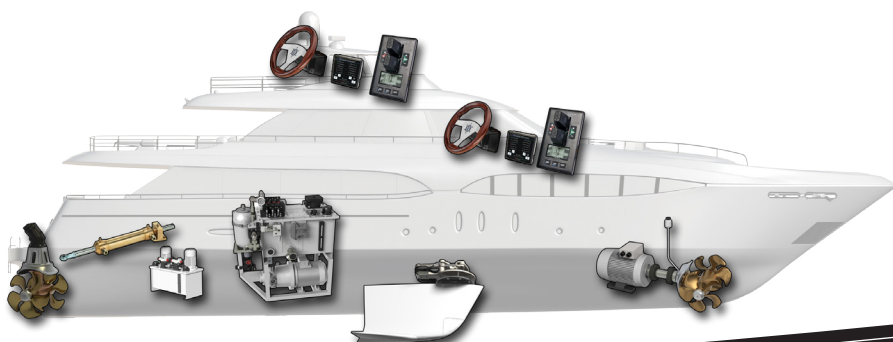
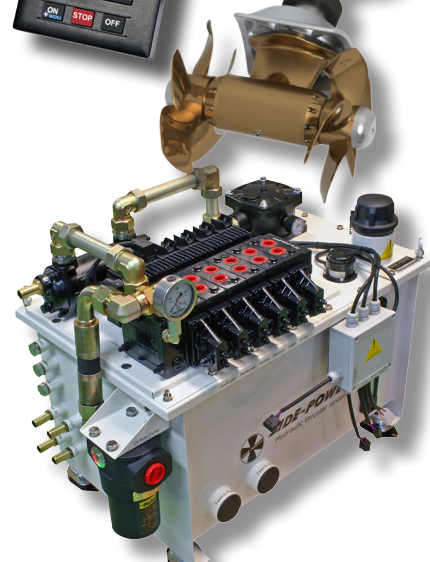
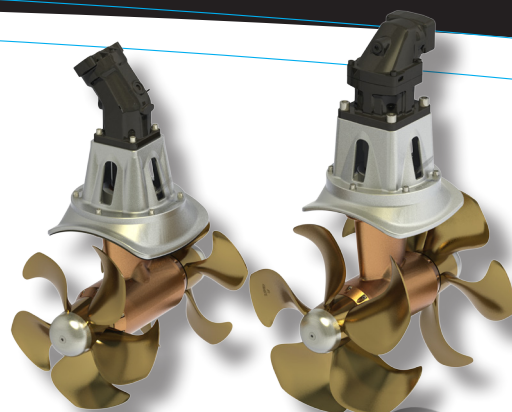

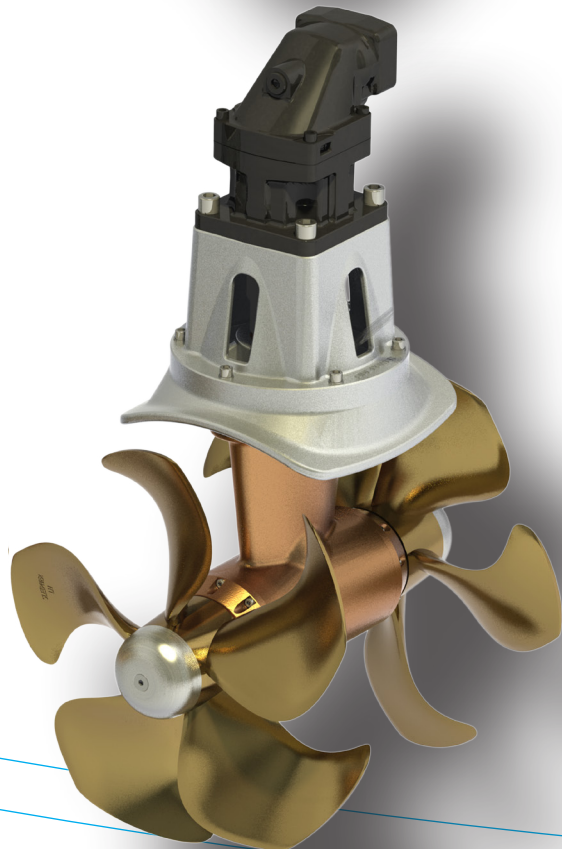
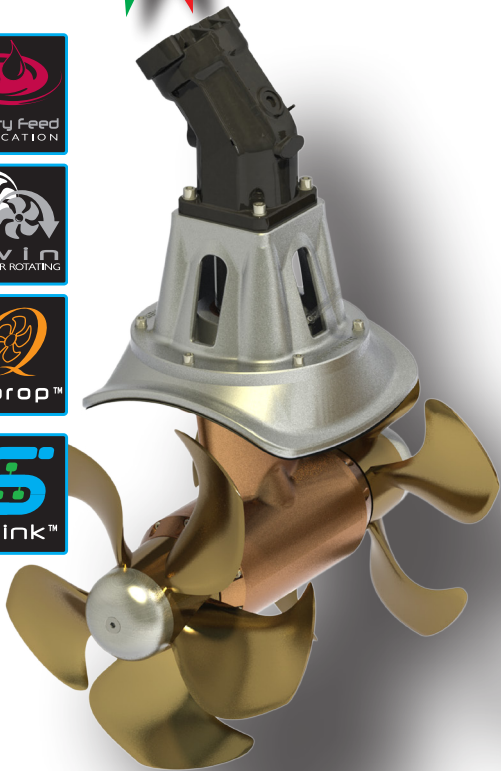

Description	SH1000/513TC	SH1400/610TC
Typical boat size (m•ft):	30 - 43 • 100 - 140	40 - 52 • 130 - 170
Tunnel inside diameter:	513mm/20"	609,6mm/24"
Propulsion system:	Counter rotating	Counter rotating
Weight:	146,5 kg/323 lbs.	170 kg/375 lbs.

Weight stated include thruster, props & bellhousing ONLY.
Weight of hydraulic motor (typical 25 - 40 kg) comes in addition

Gearleg:

- Seawater resistant bronze, CNC machined in one process to ensure 100% correct tolerances, angles and measurements.
- Oil filled with header tank and breathing to ensure long lifetime and no contamination of oil.
- Marine grade seals with protective lip and mechanically protected by special propeller hub design. Hardened and ground precision spiro-conical gears.
- Propeller shaft with double ball bearings fitted in correct tolerances.
- Driveshaft with ball bearing and special sleeve bearing in correct tolerances.
- 5 bladed bronze "Q-prop" propeller, skewback design.
- Zinc anode protection directly on gearleg, easy to access and change.

Performance and specifications at one tunnel diameter depth*:

	SH1000/513TC	SH1400/610TC
Thrust:	1000 kg/2205 lbs.	1400 kg/3086 lbs.
Hydraulic power ¹⁾ :	63 kW/84.5 Hp	87,8 kW/117.7 Hp
Hydraulic motors:	80/90/110 ccm	150/160/180 ccm
Flow rating upto:	117/132/160 lit./min.	183/195/220 lit./min.
Pressure drop upto:	323/287/235 bar	288/270/240 bar

¹⁾ most hydraulic thrusters are rated at their necessary hydraulic power supply

Significant features:

- Type Approval by Det Norske Veritas (DNV) for commercial use
- Q-prop propeller - highly energy efficient and very silent
- Thruster control by the digital bus-based S-link control system



Notes !

* Actual performances will vary for each installation depending on many factors.
Specifications here given at one tunnel diameter depth and with hydraulic power at thruster as shown.





Description	SAC750/513TC	SAC1200/610TC
Typical boat size (m•ft):	27 - 40 • 90 - 130	37 - 50 • 120 - 160
Tunnel inside diameter:	513mm/20"	609,6mm/24"
Propulsion system:	Counter rotating	Counter rotating
Weight:	146,5 kg/323 lbs.	170 kg/375 lbs.

Description	SAC1000/513TC	SAC1400/610TC
Typical boat size (m•ft):	30 - 43 • 100 - 140	40 - 52 • 130 - 170
Tunnel inside diameter:	513mm/20"	609,6mm/24"
Propulsion system:	Counter rotating	Counter rotating
Weight:	146,5 kg/323 lbs.	170 kg/375 lbs.

Weight stated include thruster, props & bellhousing ONLY.
Weight of electric motor (typical 250 - 450 kg) comes in addition

Gearleg:

- Seawater resistant bronze, CNC machined in one process to ensure 100% correct tolerances, angles and measurements.
- Oil filled with header tank and breathing to ensure long lifetime and no contamination of oil.
- Marine grade seals with protective lip and mechanically protected by special propeller hub design. Hardened and ground precision spiro-conical gears.
- Propeller shaft with double ball bearings fitted in correct tolerances.
- Driveshaft with ball bearing and special sleeve bearing in correct tolerances.
- 5 bladed bronze "Q-prop" propeller, skewback design.
- Zinc anode protection directly on gearleg, easy to access and change.

Performance and specifications at one tunnel diameter depth*:

	SAC750	SAC1000	SAC1200	SAC1400
Thrust ¹⁾ :	750 kg/2205 lbs.	1000 kg/2205 lbs.	1200 kg/2205 lbs.	1400 kg/2205 lbs.
Thruster input power:	39 kW/53 Hp	59 kW/80 Hp	79 kW/107 Hp	83 kW/112 Hp

¹⁾ See table for setup options

Significant features:

- Type Approval by Det Norske Veritas (DNV) for commercial use
- Q-prop propeller - highly energy efficient and very silent
- Thruster control by the digital bus-based S-link control system
- High quality marine standard flexible motor coupling



Notes !

* Actual performances will vary for each installation depending on many factors.
Specifications here given at one tunnel diameter depth and with thruster input power as shown.

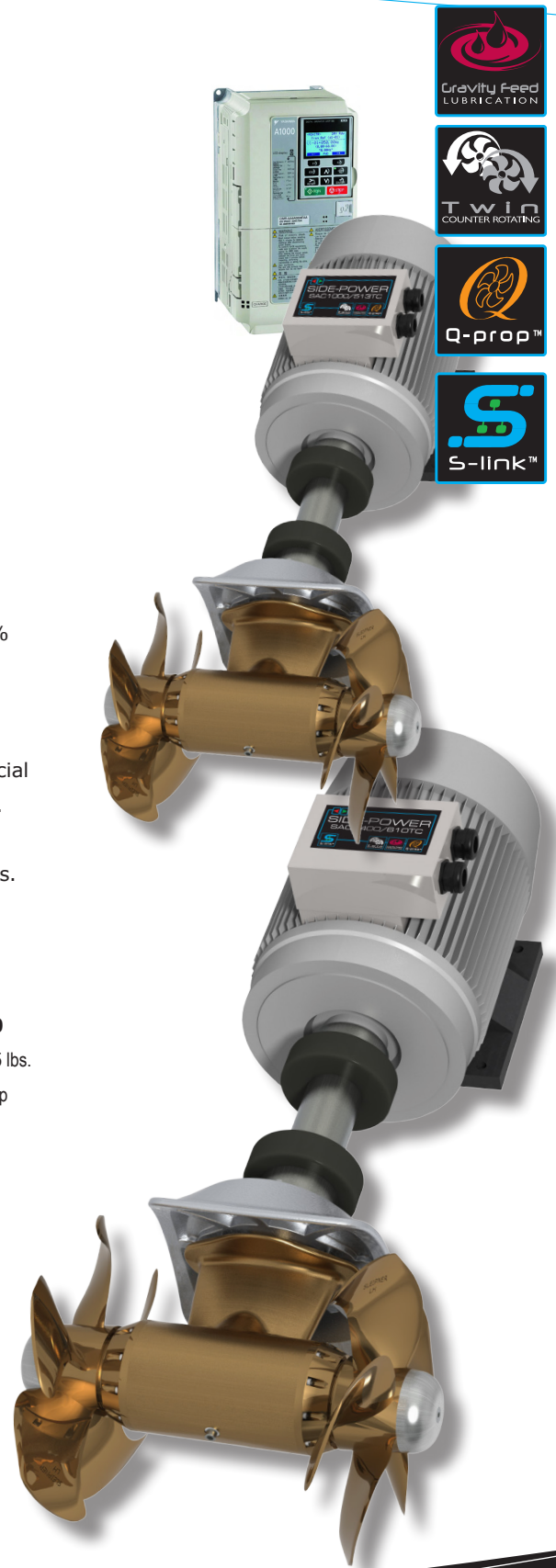

Measurements Hydraulic

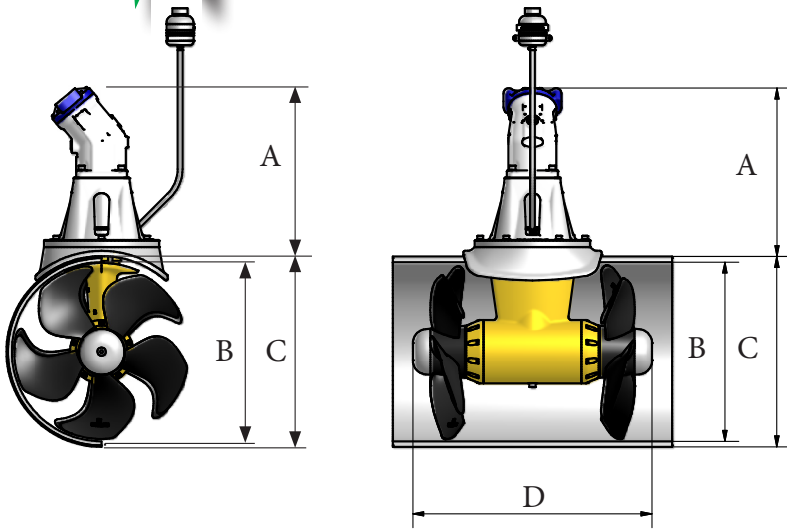

	SH1000	SH1400
A	483mm*	500mm**
B	513mm	609.60mm
C	545mm	645.60mm
D	685mm	685mm

* Height with 110 ccm Bent Axis Hydraulic motor

** Height with 150 ccm Bent Axis Hydraulic motor

Measurements AC

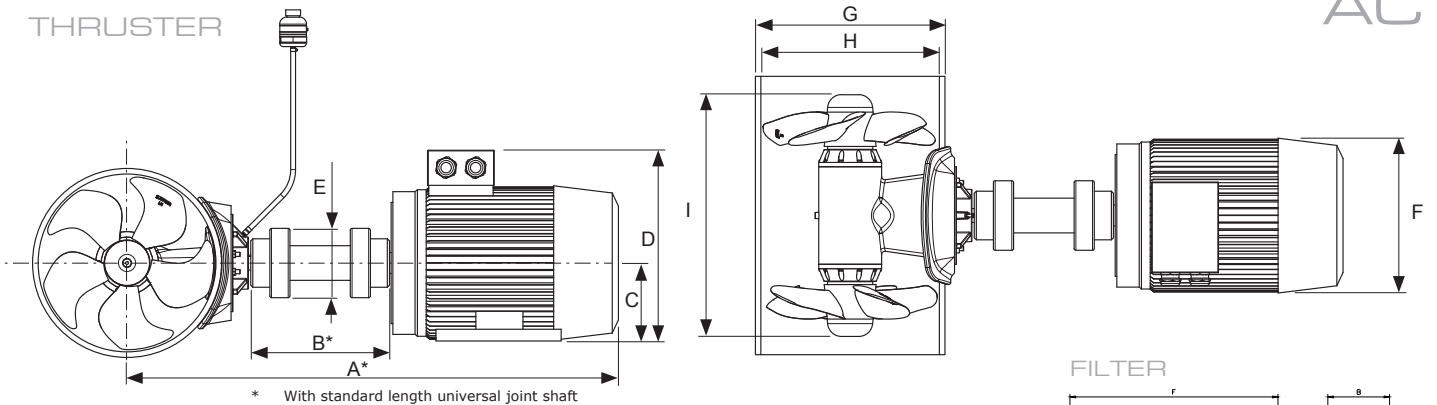

* With standard length universal joint shaft

MODEL	A (mm)	B (mm)	C (mm)	D (mm)	E (mm)	F (mm)	G (mm)	H (mm)	I (mm)	Weight compl. unit (Kg)
SAC750	1270	257	200	500	170	402	545	513	685	407
SAC750PRO	1390	313	225	550	200	445	545	513	685	480
SAC1000	1390	313	225	550	200	445	545	513	685	475
SAC1000PRO	1450	313	225	550	200	445	545	513	685	510
SAC1200	1450	313	225	550	200	445	545	513	685	510
SAC1200PRO	1450	313	225	550	200	445	545	513	685	510
SAC1400	1610	313	250	642	205	495	646	610	685	665
SAC1400PRO	1610	313	280	712	205	555	646	610	685	1730

FILTER

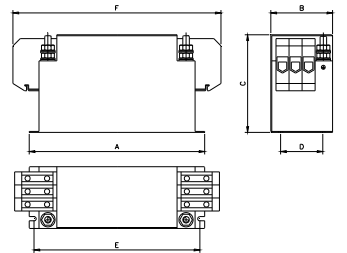

A (mm)	B (mm)	C (mm)	D (mm)	E (mm)	F (mm)
450	155	220	125	435	525

VFD

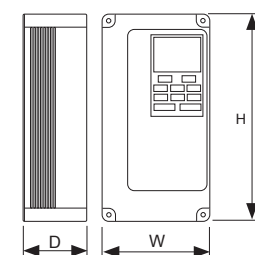

MODEL	W x D x H
SAC750:	325x258x210
SAC1000:	550x325x253
SAC1200:	550x325x253
SAC1400:	550x325x253
SAC1000:	550x325x253



Yachts & Commercial vessels

Side-Power equipment has found its way into a wide range of vessels, both in the Superyacht and commercial segment.

The unique advantages made possible by a common digital control bus enables systems to be tailor-made for almost any application.

Service and spare parts are available through our worldwide distributor network along with valuable product knowledge for advice on suitable solutions for every need.



Visit our webpage
www.side-power.com
for more examples and
user experiences!



Other catalogs:

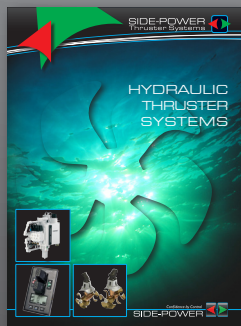

Hydraulic
Systems



Steering
Systems



Stabilizer
Systems



Superyacht
Products

Worldwide sales and service



Sleipner Motor AS

P.O. Box 519 • N-1612 Fredrikstad, Norway
Tel: +47 69 30 00 60 • Fax: +47 69 30 00 70

www.side-power.com



Confidence by Control

[SIDE-POWER.com](http://www.SIDE-POWER.com)