



ML SERIES

AUTOMATIC CHARGING RELAY

AUTOMATICALLY MANAGES THE CHARGING OF TWO LARGE BATTERY BANKS AND OFFERS OPTIONAL MANUAL OVERRIDE FOR EMERGENCY BATTERY PARALLELING

- 500 Ampere continuous rating
- Magnetic Latching (ML) draws very low current in the ON state
- Start Isolation (SI) can be configured for temporary isolation of House loads from Engine circuit during engine cranking to protect sensitive electronics
- Engine Isolation (EI) can be configured for isolation of two engines while both are running to protect engine electronics and maximize alternator output
- Manual override knob provides an added level of safety allowing manual ON-OFF control with or without power while offering LOCKED OFF capability for servicing the electrical system
- Dual sensing senses charging on two battery banks
- LED output to remotely indicate when batteries are COMBINED or ISOLATED (requires optional LED)
- Tin-plated copper studs for maximum conductivity and corrosion resistance
- Silver alloy contacts provide high reliability for switching live loads
- Label recesses for circuit identification
 - large format label in front for ACR function
 - square format labels on each side for terminal identification



LINK BUS PN 9160 for easy connection to the ML-Series Remote Battery Switch



PN 7622



Stripped Wire Termination provided on retail packaged units

Part Numbers	Volts	Manual Override Knob	Retail Packaged	Weight lb (kg)
7622	12V	Yes	Yes	1.75 (0.79)
7622100B	12V	Yes	No	1.75 (0.79)
7623	24V	Yes	Yes	1.75 (0.79)
7623100B	24V	Yes	No	1.75 (0.79)
7620	12V	No	Yes	1.69 (0.77)
7620100B	12V	No	No	1.69 (0.77)
7621	24V	No	Yes	1.69 (0.77)
7621100B	24V	No	No	1.69 (0.77)

Deutsch DTM Connector provided on bulk packaged units. Other connector plugs are available for high volume OEM applications

ML-Series Remote Control Contura Switch PN 2146



Included with retail packaged unit

ML-SERIES

AUTOMATIC CHARGING RELAY

Specifications

Cranking Rating: 10 sec.	2,500 Amps
Intermittent Rating: 5 min.	See table below
Continuous Rating	See table below
Amperage Operating Current	<40mA continuous <7.0A when changing states
Maximum Circuit Voltage Rating	32V DC
Live Current Switching	300A @ 12V DC-10,000 Cycles
Terminal Stud Size	3/8"-16
Recommended Ring Terminal	3/8" (M10)
Maximum Terminal Stud Torque	140 in-lb (15.5 N-m)
Control Circuit Current Draw	<100mA when changing states

Relay Contact Position:

-Combine (30 sec.)	13.5V @ 12V DC 27.0V @ 24V DC
-Combine (90 sec.)	13.0V @ 12V DC 26.0V @ 24V DC
-Open Low (10 sec.)	12.35V @ 12V DC 24.7V @ 24V DC
-Open Low (30 sec.)	12.75V @ 12V DC 25.5V @ 24V DC
-Open High	16.2V @ 12V DC 32.4V @ 24V DC

Regulatory

IP Meets ISO 8846 ignition protection, and SAE J1171 external ignition protection requirements

66 IP66—Protected against powerful water jets

CE marked

Wire Size	Intermittent Rating	Continuous Rating
2/0	400A	225A
4/0	400A	300A
2x (4/0)	700A	500A

Remote Control Contura Switch

Contura Control Switch	Sustained SPDT ON-OFF-ON
Seals	Internal & External Gasket Panel Seal
Operating Temperature Range	-40°C to 85°C
Mounting Cut-out	1.450" x 0.830" (36.83mm x 21.08mm)
LED Rating	100,000 hours 1/2 life

Regulatory

IP Meets ISO 8846 and UL 1500 external ignition protection requirements

67 IP67—Protected against immersion up to 1 meter for 30 minutes

Specifications subject to change.
See www.blueseasystems.com for additional information and specifications.

6838 Rev.003

AUTOMATIC CHARGING RELAY

Start Isolation Installation Diagram with Remote Control Contura Switch (PN 2146)

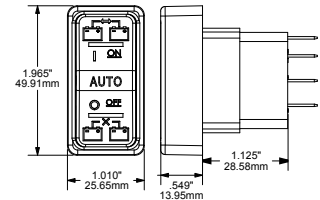
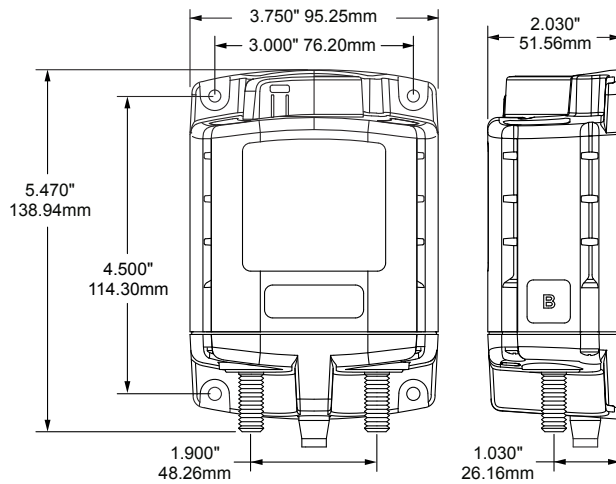
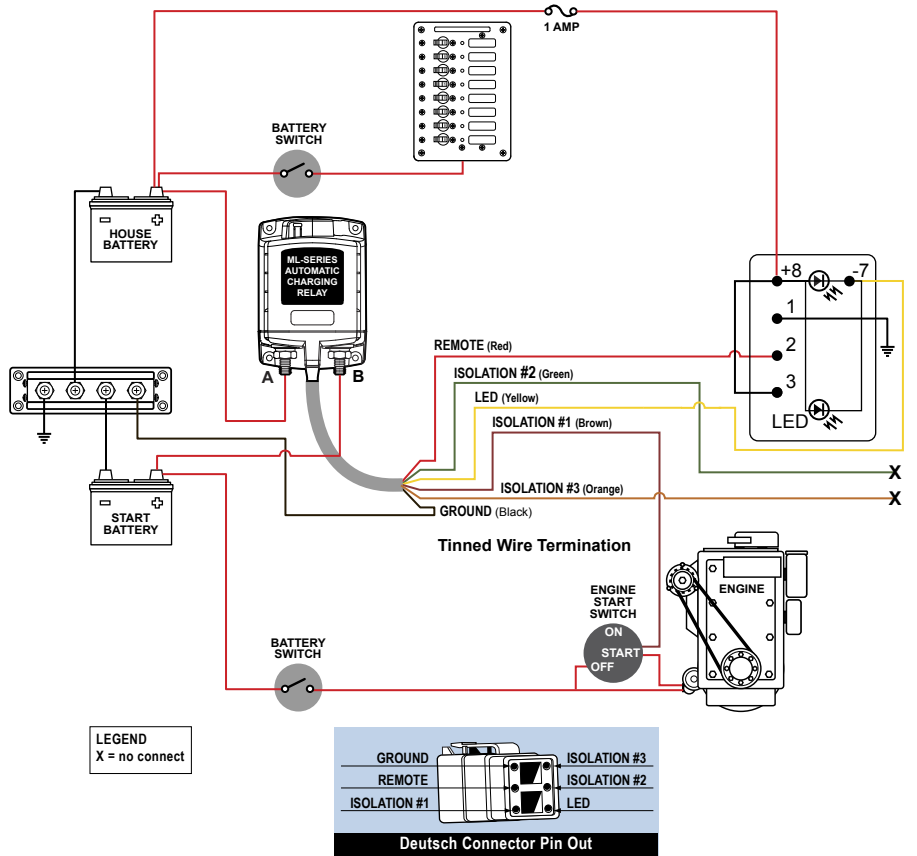

425 Sequoia Drive Bellingham, WA 98226 USA

800-222-7617 (USA and Canada)

Phone: 360-738-8230 Fax: 360-734-4195

www.blueseasystems.com