

15	1	TRILLINGDEMPERS 50X40MM M10/M12	50201830	50201830
14	1	Siphon hose Piccolo	7036P184495	50220132
13	2	Knie BiBi 1-2"	50221072	50221072
12	2	Nipple 1-2	50221122	50221122
11	4	Hose Connector M 1/2" x 20mm	50221007	50221007
10	2	Socket 1-2	50221094	50221094
9	1	Foam 15mm Bottem Canopy Picc6	7535P238569	50222002
8	2	Hose Connector F 1/2" x 20mm	50221021	50221021
7	6	Washer M20	7036P184375	50211415
6	1	Exhaust Pipe flash exhaust 33mm Silicone (Dry - Wet)	7511P153004	50230593
5	16	Prevailing torque type hexagon nut with non-metallic insert DIN 985 Steel Zinc plated 5 M8	12300080001	50211475
4	16	Fender washer Steel Zinc plated M8X25	38400080025	50211436
3	16	Hexagon socket countersunk head screw ISO 10642 Steel Zinc plated 010.9 M8X25	7405080025	50211538
2	2	Strip foundation Piccolo GV2	7046P174145	NOT REQUIRED
1	1	Base	7535P220002	NOT_REQUIRED

ITEM NO.	QTY.	DESCRIPTION	DRAWING	ARTICLE No.														
UNLESS OTHERWISE SPECIFIED: CHAMFER SHARP EDGES GENERAL TOLERANCE NEN ISO 2768-m FORM AND PLACE TOLERANCES NEN-ISO 1101 WELDING SYMBOL NEN EN 22553 ROUGHNESS ACC. to NEN3634		TOLERANCE PRINCIPE ISO 8015	FINISH: -	DO NOT SCALE DRAWING														
PROJECTION : THIRD ANGLE UNITS : mm			MATERIAL:	SHEET FORMAT: A3														
<table border="1"> <tr> <th>NAME</th> <th>SIGNATURE</th> <th>DATE</th> <th>STATUS:</th> </tr> <tr> <td>DRAWN</td> <td>H.J.V.</td> <td>22-2-2023</td> <td>Design</td> </tr> <tr> <td>CHK'D</td> <td>-</td> <td>-</td> <td>-</td> </tr> <tr> <td>PRINTED</td> <td>-</td> <td>25-5-2023</td> <td>-</td> </tr> </table>			NAME	SIGNATURE	DATE	STATUS:	DRAWN	H.J.V.	22-2-2023	Design	CHK'D	-	-	-	PRINTED	-	25-5-2023	-
NAME	SIGNATURE	DATE	STATUS:															
DRAWN	H.J.V.	22-2-2023	Design															
CHK'D	-	-	-															
PRINTED	-	25-5-2023	-															
DRAWING: 7046A228207			ARTICLE NO. NOT_REQUIRED	REVISION														
Weight: 11044.00 gram			SCALE:1:5	SHEET 1 OF 1														

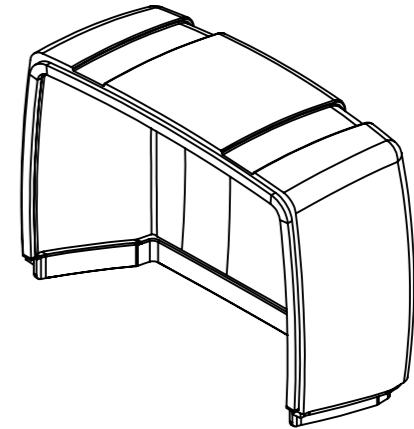
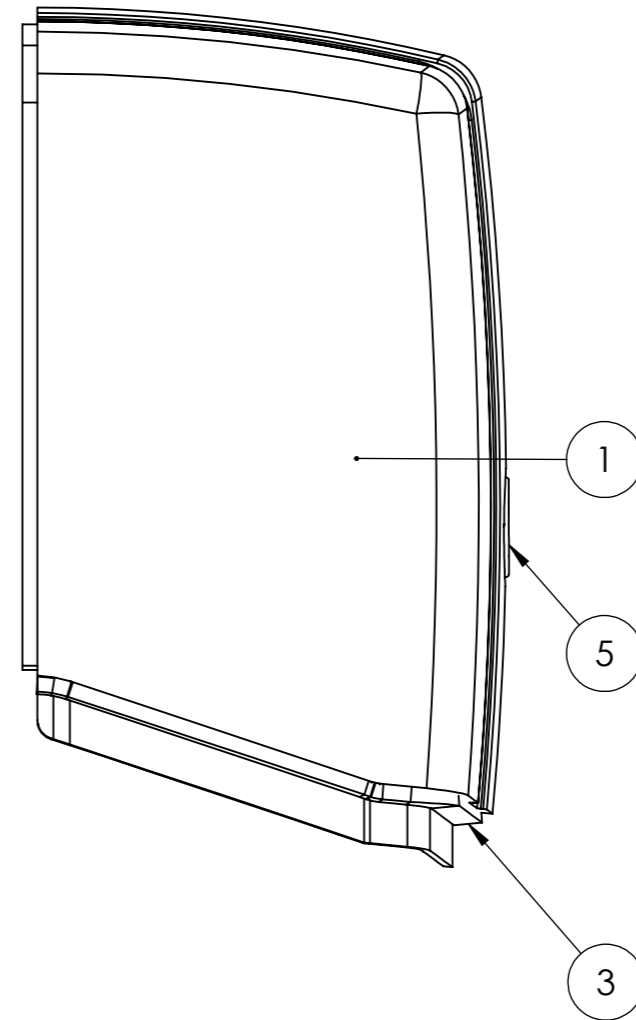
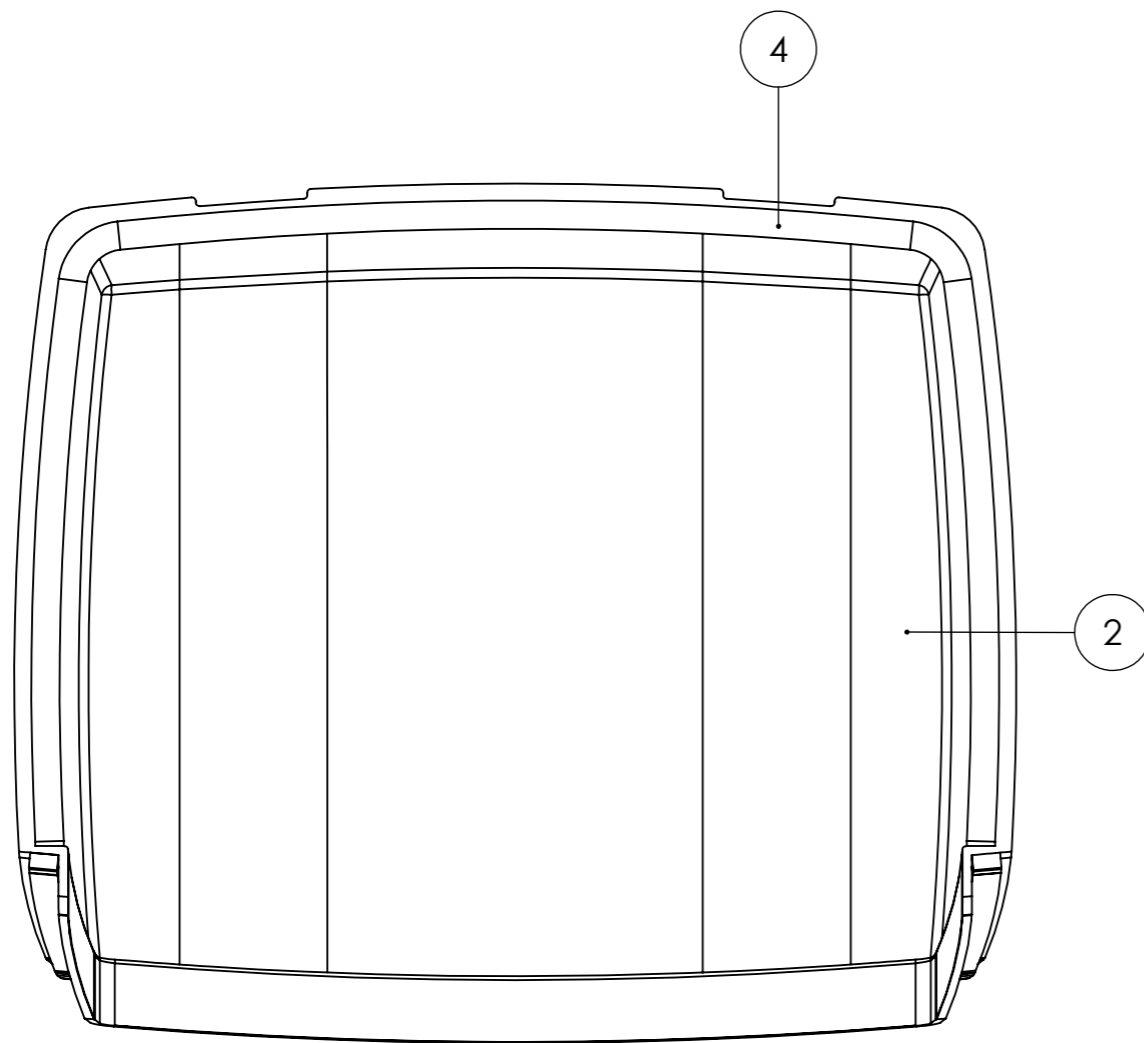

Per machine:

- 1 Kap met [Pos.4]
- 1 Kap zonder [Pos.4]

5	1	Whisper Power Logo 2015 120mm	9003P152793	40200951	
4	1	Neoprene seal Preglued 15x8mm P-M	7535P238573	50222005	
3	1	Neoprene Seal Preglued 15x8 P-M	7535P238572	50222005	
2	1	Insulation 15mm Canopy GV2-Compact	7535P238570	50222002	
1	1	Canopy	7535P220003	NOT_REQUIRED	
ITEM NO.	QTY.	DESCRIPTION	DRAWING	ARTICLE No.	
UNLESS OTHERWISE SPECIFIED: CHAMFER SHARP EDGES GENERAL TOLERANCE NEN ISO 2768-m FORM AND PLACE TOLERANCES NEN-ISO 1101 WELDING SYMBOL NEN EN 22553 ROUGHNESS ACC. to NEN3634		TOLERANCE PRINCIPLE ISO 8015 PROJECTION : THIRD ANGLE UNITS : mm	FINISH: - Material:	DO NOT SCALE DRAWING SHEET FORMAT: A3 TITLE: Canopy with insulation Piccolo 6	
		NAME	SIGNATURE	DATE	STATUS: Design
DRAWN	H.J.V.			22-2-2023	
CHK'D	-			-	
					DRAWING: 7046A238571
PRINTED				22-2-2023	
					Weight: 10976.82 gram
			ARTICLE NO.	REVISION	
			NOT_REQUIRED		
			SCALE:1:4	SHEET 1 OF 1	



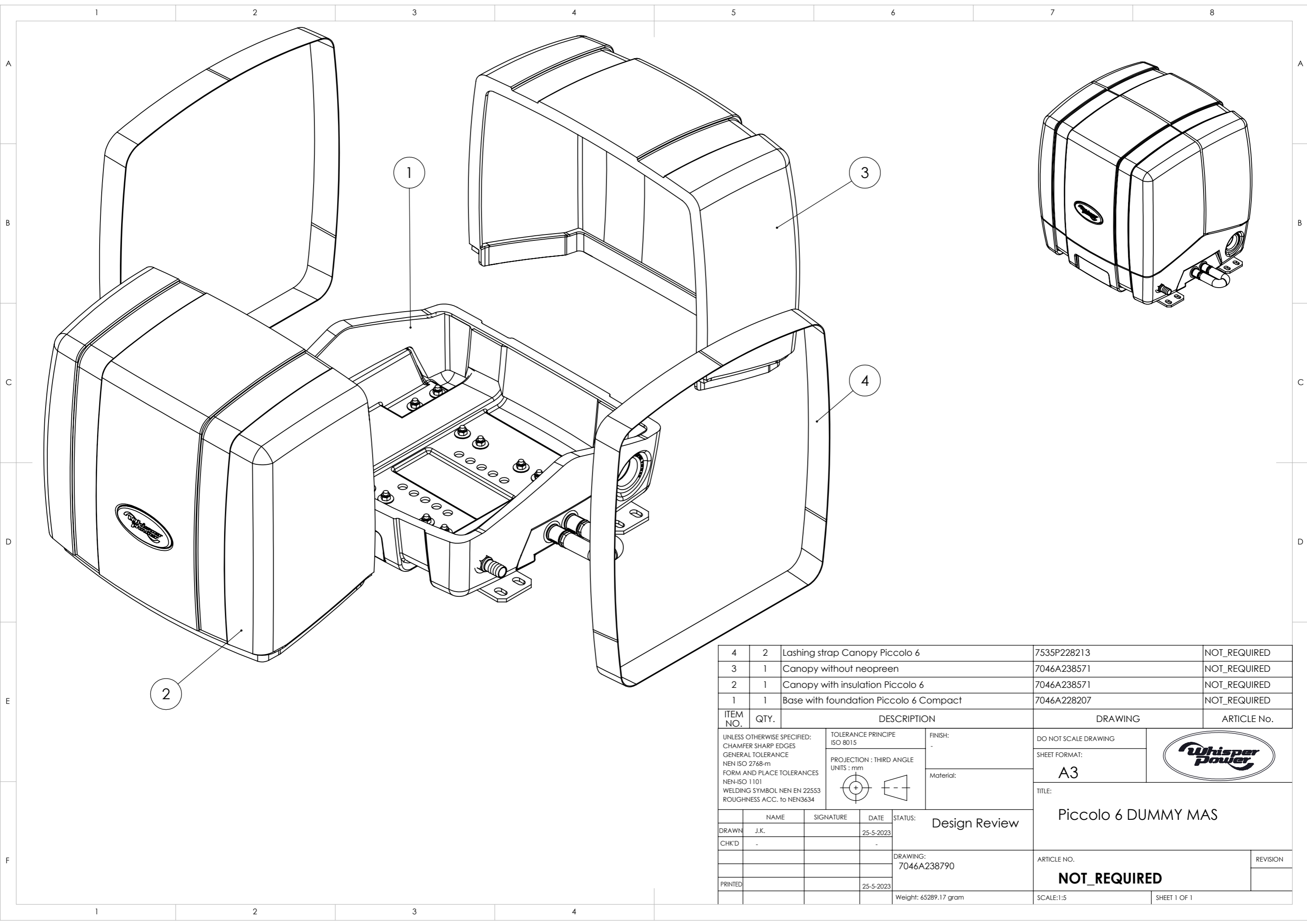

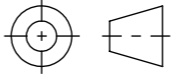
4	2	Lashing strap Canopy Piccolo 6	7535P228213	NOT_REQUIRED
3	1	Canopy without neopren	7046A238571	NOT_REQUIRED
2	1	Canopy with insulation Piccolo 6	7046A238571	NOT_REQUIRED
1	1	Base with foundation Piccolo 6 Compact	7046A228207	NOT_REQUIRED
ITEM NO.	QTY.	DESCRIPTION	DRAWING	ARTICLE No.
UNLESS OTHERWISE SPECIFIED: CHAMFER SHARP EDGES GENERAL TOLERANCE NEN ISO 2768-m FORM AND PLACE TOLERANCES NEN-ISO 1101 WELDING SYMBOL NEN EN 22553 ROUGHNESS ACC. to NEN3634		TOLERANCE PRINCIPLE ISO 8015 PROJECTION : THIRD ANGLE UNITS : mm 	FINISH: - Material:	DO NOT SCALE DRAWING SHEET FORMAT: A3 TITLE: Piccolo 6 DUMMY MAS
	NAME	SIGNATURE	DATE	STATUS:
DRAWN	J.K.		25-5-2023	Design Review
CHK'D	-		-	
				DRAWING: 7046A238790
PRINTED			25-5-2023	ARTICLE NO. NOT_REQUIRED
			Weight: 65289.17 gram	REVISION
			SCALE:1:5	SHEET 1 OF 1



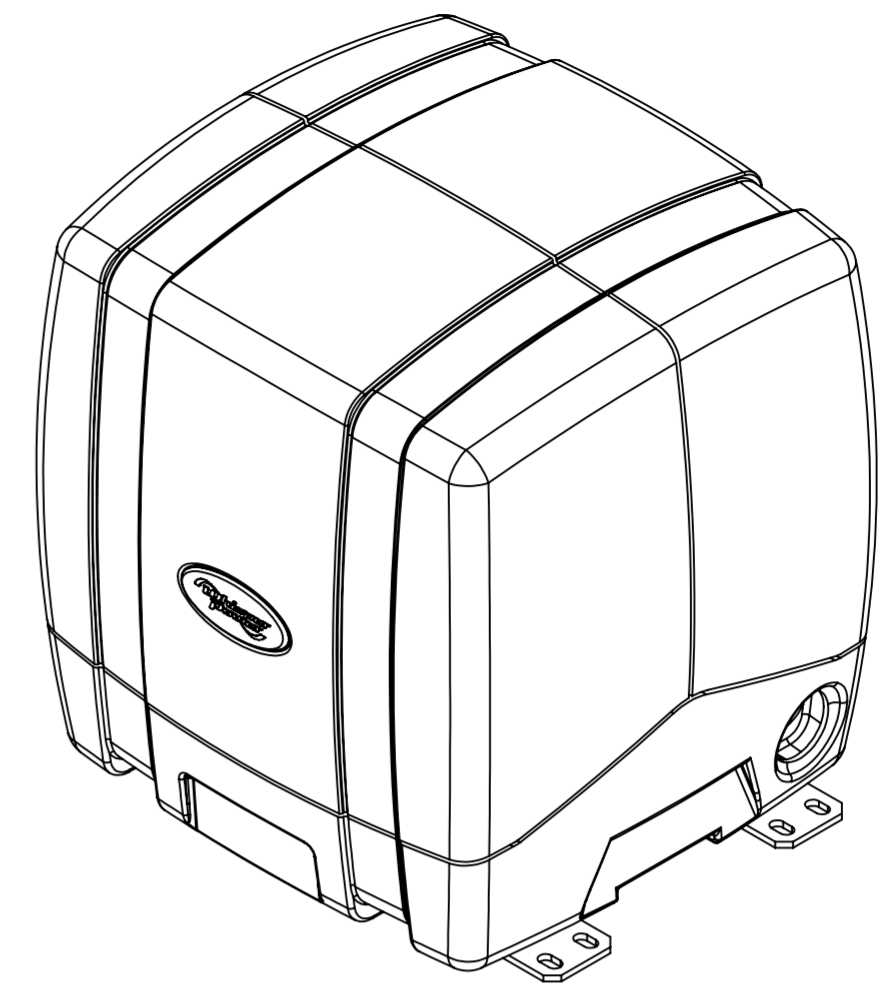
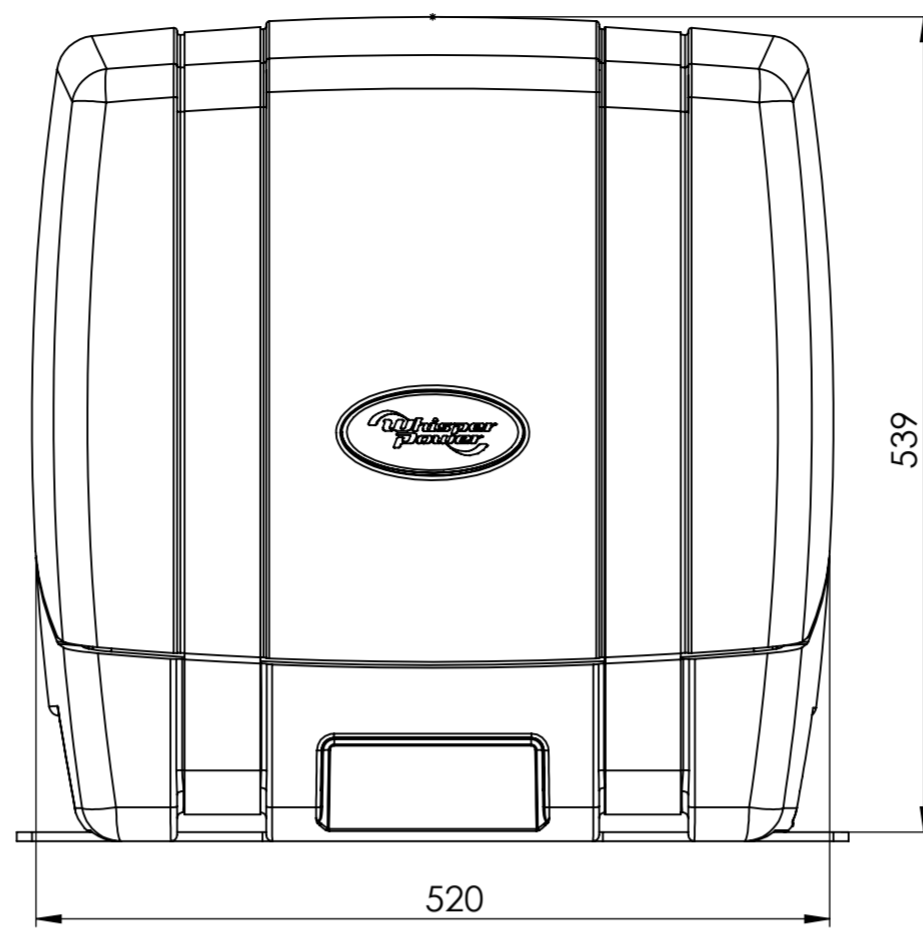
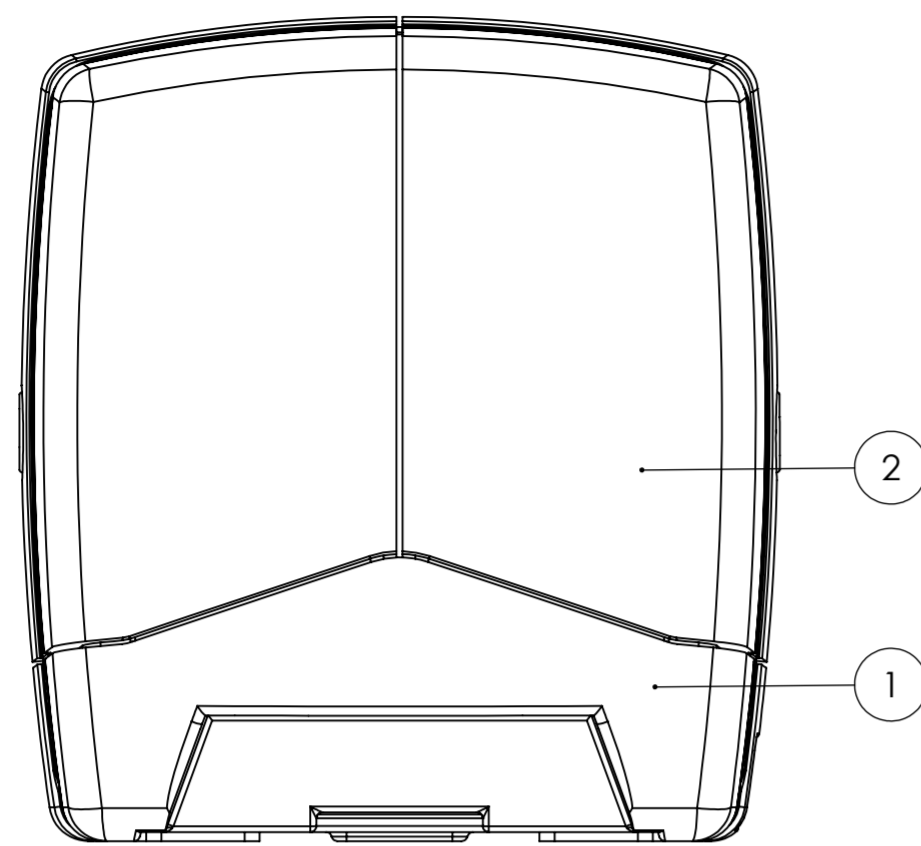

Scale 1:5

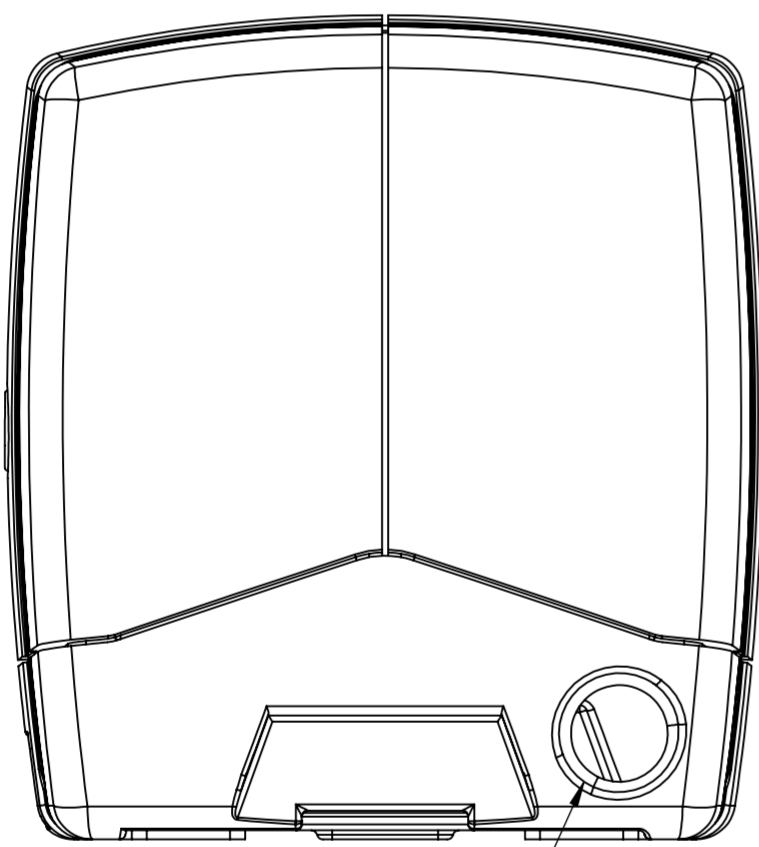

Exhasut
Marine Ø40 Hose connection

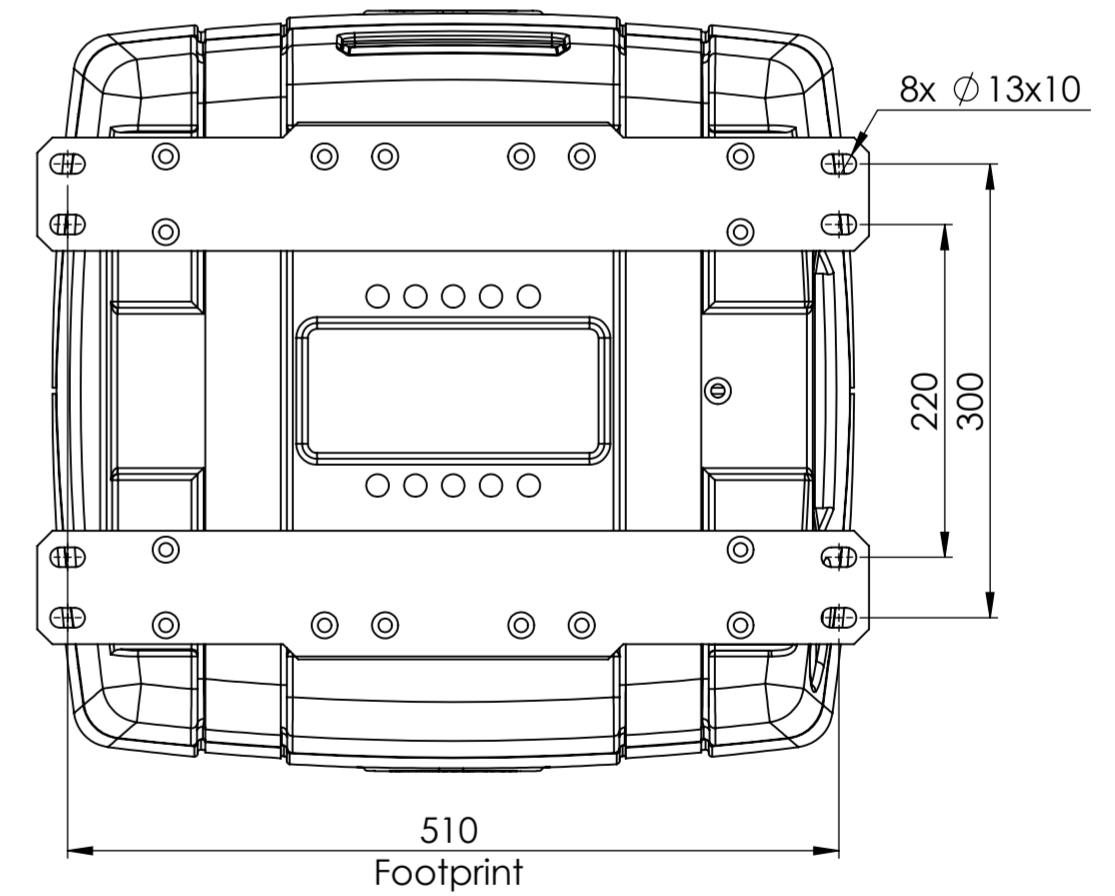
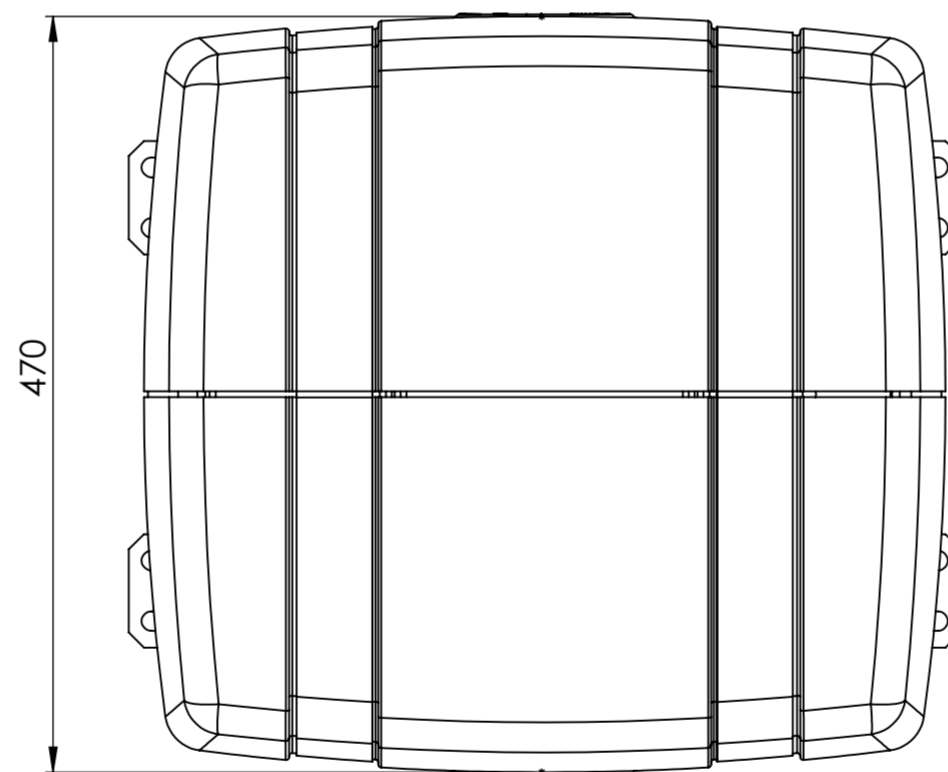

Piccolo 6 Compact

UNLESS OTHERWISE SPECIFIED: CHAMFER SHARP EDGES GENERAL TOLERANCE NEN ISO 2768-m FORM AND PLACE TOLERANCES NEN-ISO 1101 WELDING SYMBOL NEN EN 22553 ROUGHNESS ACC. to NEN3634		TOLERANCE PRINCIPLE ISO 8015		FINISH: -		DO NOT SCALE DRAWING		
PROJECTION : THIRD ANGLE UNITS : mm		Material:		SHEET FORMAT: A2		TITLE: Polyester Base - Canopy Uitzet		
DRAWN H.J.V.	SIGNATURE	DATE 27-9-2022	STATUS: Design		DRAWING: 7535A228192		ARTICLE NO. NOT_REQUIRED	REVISION
CHKD -					Weight: 9331.09 gram		SCALE:1:5	SHEET 1 OF 1