

# Installation Manual

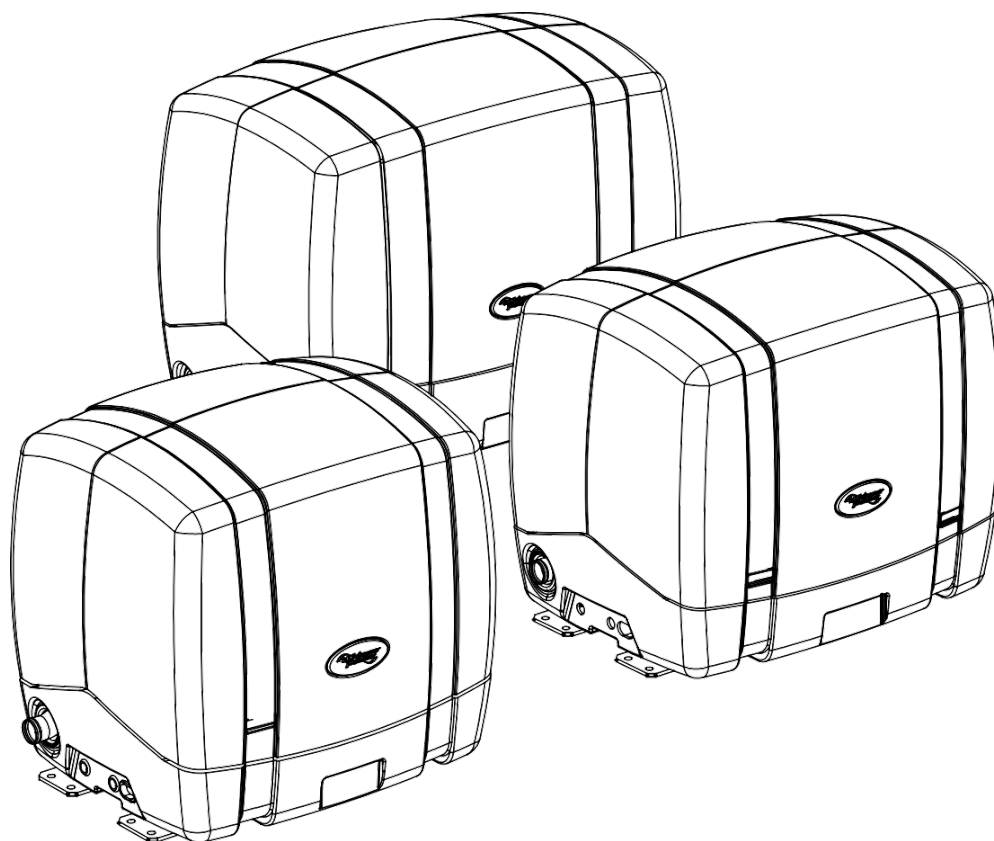

## Marine Diesel Piccolo Genverter

Piccolo GV 2 | 3 | 3+ Piccolo 8 | 10 | 12 | 15 | 18

[whisperpower.com](http://whisperpower.com)



# 1 CONTENTS

<b>1</b>	<b>INTRODUCTION .....</b>	<b>5</b>
1.1	USE OF THIS MANUAL.....	5
1.2	VALIDITY OF THIS MANUAL.....	5
1.3	INSTALLATION PARTS.....	5
<b>2</b>	<b>INSTALLATION.....</b>	<b>5</b>
2.1	GENERAL.....	5
2.2	LOCATION.....	5
2.3	PROTECTION AGAINST DIRT, SAND AND BAD WEATHER CONDITIONS.....	6
2.4	SOUND AND VIBRATION REDUCTION.....	6
2.4.1	Further recommendations.....	6
2.5	VENTILATION.....	6
2.6	CONNECTIONS.....	7
2.7	FUEL SUPPLY.....	8
2.7.1	Fuel tank.....	8
2.7.2	Fuel lift pump.....	8
2.7.3	Fuel pipes.....	8
2.7.4	Fuel filters.....	9
2.8	COOLING.....	9
2.8.1	General.....	9
2.8.2	The internal cooling system.....	9
2.8.3	Keel cooling.....	9
2.8.4	Intercooling.....	9
2.9	WET EXHAUST SYSTEM.....	11
2.9.1	General.....	11
2.9.2	Standard exhaust system.....	11
2.9.3	Super silent exhaust system.....	11
<b>3</b>	<b>ELECTRICAL INSTALLATION.....</b>	<b>13</b>
3.1	DIGITAL DIESEL CONTROL SYSTEM.....	13
3.1.1	General.....	13
3.1.2	Remote control.....	13
3.1.3	Acoustic alarm or warning lamp.....	13
3.1.4	Connection for emergency stop / fire alarm switch.....	13
3.1.5	Automatic starting and stopping.....	14
3.1.6	General.....	14
3.1.7	Start/stop by external switch.....	14
3.1.8	STARTER BATTERY.....	14
3.2	OTHER RECOMMENDATIONS AND WARNINGS.....	15
3.3	ALTERNATING CURRENT.....	15
3.4	CABLE PROTECTION (FUSES).....	15
3.5	GROUNDING.....	15
3.6	CABLE.....	15

<b>4</b>	<b>INSTALLATION SUMMARY.....</b>	<b>16</b>
4.1	GENERAL.....	16
4.2	COMMISSIONING TABLE.....	16
4.3	TECHNICAL DATA.....	16
4.4	SPECIFICATION OF THE ACCESSORIES.....	16
4.5	INSTALLATION MATERIALS.....	17
<b>5</b>	<b>DIAGRAMS &amp; DRAWINGS .....</b>	<b>21</b>
5.1	ELECTRICAL DIAGRAMS.....	21
5.2	MECHANICAL DRAWINGS.....	29

# 1 INTRODUCTION

## 1.1 USE OF THIS MANUAL

This manual serves as a guideline for the safe and effective installation of the WhisperPower genverters for marine applications.

It is obligatory that every person who is involved with the installation of the genverter must be completely familiar with the contents of this manual, and that he/she carefully follows the instructions contained herein.

The information, specifications, illustrations and statements contained within this publication are given with our best intentions and are believed to be correct at the time of going to press.

Our policy is one of continued development and we reserve the right to amend any technical information without prior notice.

Whilst every effort is made to ensure the accuracy of the particulars contained within this publication neither the manufacturer, distributor, or dealer in any circumstances shall be held liable for any inaccuracy or the consequences thereof.

Keep this manual in a secure place!

## 1.2 VALIDITY OF THIS MANUAL

All of the specifications, provisions and instructions contained in this manual apply solely to standard versions of genverters delivered by WhisperPower.

This manual is valid for the following models:

Description	
<b>24/48 VDC</b>	
Piccolo GV2	(Kubota Z482)
Piccolo GV3	(Kubota D722)
Piccolo GV3+	(Kubota D1105)
<b>230/120 VAC</b>	
Piccolo 8	(Kubota Z482)
Piccolo 10	(Kubota D722)
Piccolo 10	(Kubota D722)
Piccolo 12	(Kubota D722)
Piccolo 15	(Kubota D1105)
Piccolo 18	(Kubota V1505)

Refer to the user’s manual for identification of the genverter. For other models see our website: [www.whisperpower.com](http://www.whisperpower.com).



### WARNING

During installation and commissioning of the genverter, the Safety Guidelines & Measures are applicable at all times. See Chapter 2 of the user’s manual.



### WARNING

A warning symbol draws attention to special warnings, instructions or procedures which, if not strictly observed, may result in damage or destruction of equipment, severe personal injury or loss of life.



### DANGER

This danger symbol refers to electric danger and draws attention to special warnings, instructions or procedures which, if not strictly observed, may result in electrical shock which will result in severe personal injury or loss of life.



### WARNING

Before working on the system read the safety instructions in the user’s manual.

## 1.3 INSTALLATION PARTS

Besides the parts that are included with the delivery you need at least the parts listed at section 4.4 to install the genverter. Please note that this listing may not be complete, as every installation differs from the other. Oil is not included in the supply. Refer to the user’s manual for the right specifications.

# 2 INSTALLATION

## 2.1 GENERAL

To ensure reliability and durability of the equipment, it is very important that the installation is carried out with the utmost care and attention. To avoid problems, such as temperature problems, noise levels, vibration, etc. The instructions set out in this manual must be followed and all installation work must be carried out only by qualified, authorized and trained personnel, consistent with the locally applicable standards and taking into consideration the safety guidelines and measures (Chapter 2 of the user’s manual).



### WARNING!

The genverter incorporates powerful permanent magnets. Cardiac patients, especially those living with a pacemaker, should bear this in mind.

## 2.2 LOCATION

When looking for a proper place for a WhisperPower Piccolo-genverter in a vessel all relevant aspects have to be taken into account

- Accessibility
- Solid foundation
- Space to mount the exhaust (refer to 2.9)
- A route to fit the fuel lines
- Combustion air supply (refer to 2.5)

Because of their small dimensions, WhisperPower genverters can

be installed in tight locations. Please consider that even almost maintenance-free machinery must still remain accessible.

When selecting the location for the genverter, make sure there is sufficient room to carry out any maintenance work. The unit must be easily accessible on the service side.

All models can be serviced from one side. Oil filling can be done on the service side and on the top. The top of the engine (rocker cover) has to be accessible for adjustment of the valve clearance.

Please also note that in spite of the automatic oil pressure switch the oil level must be checked regularly.

### 2.3 PROTECTION AGAINST DIRT, SAND AND BAD WEATHER CONDITIONS

The unit is designed to be mounted inside a vessel rather than on deck, where it could be exposed to (salt) water spray and bad weather conditions. The best place is a dedicated engine room. Even there, it should be protected against bilge water, condensation, frost and other conditions that may affect the engine and electronics.

The air inlet of the engine room must be protected against the ingress of water and it is recommended to fit an air inlet strainer for protection against dirt and dust.

### 2.4 SOUND AND VIBRATION REDUCTION

Position the genverter as low as possible in the vessel. The genverter is secured to the base frame inside the canopy by means of a flexible engine mountings system. This frame is must be solidly mounted in the vessel, not using rubber mountings again unless an additional base plate is inserted. When it is possible to mount the unit directly on the vessel's frames this has advantages in preventing vibrations by resonance.

#### 2.4.1 Further recommendations

WhisperPower genverters are standard equipped with a sound cover canopy. This sound cover has been designed to give effective sound insulation. For optimum sound and vibration dampening, the following factors should be considered

1. Most importantly, the structure on which the genverter is placed must be stiff. Directly below the base frame, the structure should be supported by the vessel's frames. When this is not possible horizontal structures should be made stiff by additional provisions (Figure 1). In larger vessels a

separate and insulated engine room for the genverter will help to dampen the noise even further.

2. Avoid mounting the genverter in close proximity to thin walls or floors that may cause resonance.
3. Sound dampening is extremely poor if the genverter is mounted on a light weight flimsy surface such as plywood which will only amplify vibrations. If mounting on a thinner surface cannot be avoided, this should be at least be reinforced with stiffening struts or ribbing. If possible, holes should be drilled or cut through the surface to help reduce the resonance. Covering the surrounding walls and floors with a heavy coating plus foam will certainly improve the situation.
4. Never connect the base of the genverter directly to bulkheads or tanks (Figure 1).

### 2.5 VENTILATION

The genverter normally draws air from the engine room. An engine room with natural ventilation must have vent openings of adequate size and location to enable the genverter to operate without overheating. To allow an ample supply of air within the temperature limits of the genverter an opening of at least 100 cm<sup>2</sup> is required.

A "sealed" engine compartment must have a good extraction ventilator to maintain reasonable ambient temperatures. High temperature of intake air reduces engine performance and increases engine coolant temperatures. Air temperatures above 40°C reduce the engine power by 2% for each 5°C of rise. At higher temperatures the electric output will be lower. To minimize these effects the engine room temperature must not exceed the outside ambient air temperature by more than 15°C.

Apply a combination of ventilators, blowers and air intake ducting to meet the temperature limit. The air inlet ducts should run to the bottom of the engine compartment to clear fumes from the bilge and to circulate fresh air. Air outlets should be at the top of the engine compartment to evacuate the hottest air. An engine compartment blower should be used as an extraction ventilator to remove air from the engine room.

In cases where it is impossible to meet the above mentioned temperature limit by using engine compartment ventilation, connections are to be made for an air inlet directly to the genverter enclosure. With these connections the genverter can be directly connected to an air duct.

Air inlets should be louvered, where appropriate, to protect the engine room and to protect the genverter from water spray.

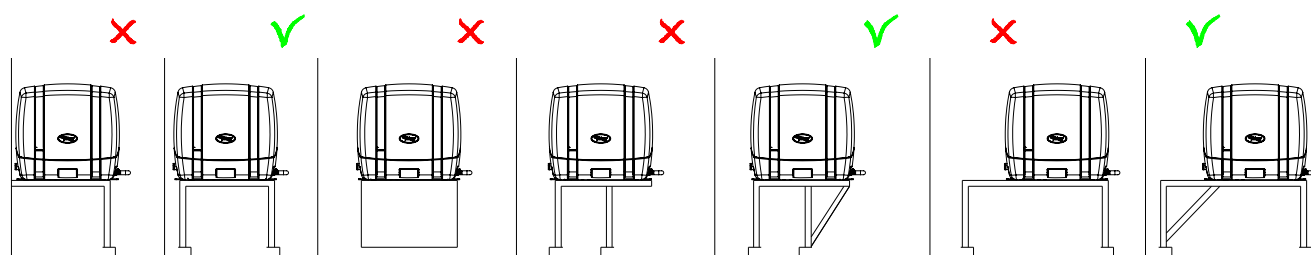

X = wrong, V = OK

Fig.1: Mounting of the WhisperPower genverter

## 2.6 CONNECTIONS

The genverter comes with all supply lines and output cables (i.e. electric cables, exhaust stub, fuel lines etc.) already connected. The supply lines are fed through the capsule's front base. The connections are marked as shown in Figure 2-4 .

Refer to Section 5.1 for a graphical overview of installation and wiring connection requirements.

All electrical connections, cable types and sizes must comply with the appropriate national regulations. Supplied cables are rated for ambient temperatures up to 70°C. If the cables are required to meet higher temperature requirements, they must be run through conduits.



**ATTENTION!**  
Before working on the system, read the safety instructions.

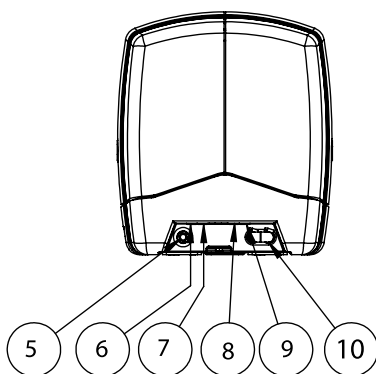
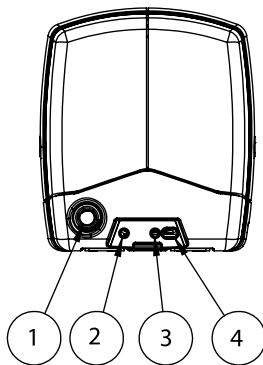
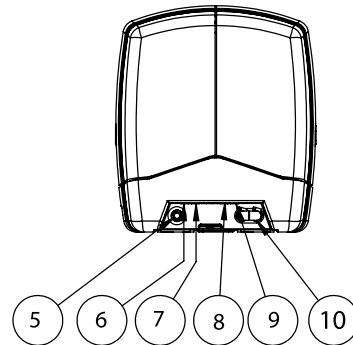
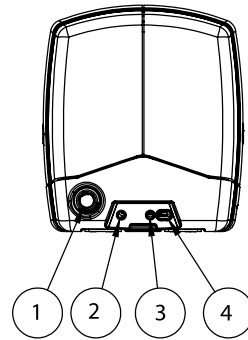

- 1 Exhaust Marine:  $\varnothing 40$  hose connection
- 2 To expansion tank
- 3 AC Power 5G6
- 4 AC Sense 4G2.5
- 5 Water in (cold) hose 20 mm
- 6 Fuel out 8mm
- 7 Fuel in 8mm
- 8 Battery + "Red" 25mm<sup>2</sup>
- 9 Battery - "Black" 25mm<sup>2</sup>
- 10 Syphon in/out 20 mm

Fig.3: Connections for Piccolo 15

- 1 Exhaust Marine:  $\varnothing 40$  hose connection
- 2 To expansion tank
- 3 AC Power
- 4 AC Sense 4G2.5
- 5 Water in (cold) hose 20 mm
- 6 Fuel out 8mm
- 7 Fuel in 8mm
- 8 Battery + "Red" 25mm<sup>2</sup>
- 9 Battery - "Black" 25mm<sup>2</sup>
- 10 Syphon in/out 20 mm

Fig.2: Connections for Piccolo 2, 3, 3+, 8, 10 and 12

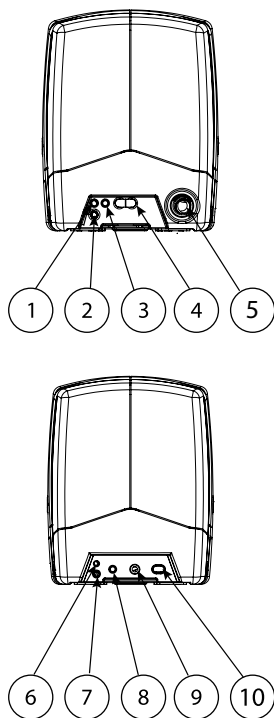

- 1 Exhaust Marine:  $\varnothing 40$  hose connection
- 2 To expansion tank
- 3 AC Power 5G6
- 4 AC Sense 4G2.5
- 5 Water in (cold) hose 20 mm
- 6 Fuel out 8mm
- 7 Fuel in 8mm
- 8 Battery + "Red" 25mm<sup>2</sup>
- 9 Battery - "Black" 25mm<sup>2</sup>
- 10 Syphon in/out 20 mm

Fig.4: Connections for Piccolo 18

## 2.7 FUEL SUPPLY

### 2.7.1 Fuel tank

Fuel tanks should be made of appropriate material such as (stainless) steel or plastic. Steel tanks should not be galvanized or painted inside. Condensation can occur in metal tanks when temperature changes. Therefore, water accumulates at the bottom of the tank and provisions should be made for the drainage of this water.

The tank will need a filling connection, a return connection and an air ventilation connection which will require protection against water entry.

Some official regulations do not allow connection points at the base of the fuel tank; connections are to be made at the top of the tank with internal tubing down to a few cm above the bottom of the tank. When using the existing fuel tank of the propulsion engine, fitting should be carried out with extra care. Both a supply line and a return line should be installed and go into the tank from the top. Interference of the two systems (propulsion engine and genverter) should be avoided. Emptying the tank below the level of the suction pipe of the genverter could make it necessary to bleed the fuel system.

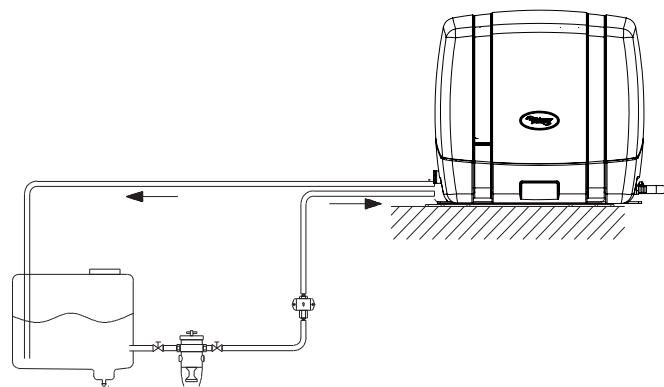

Fig.5: Fuel tank below the genverter

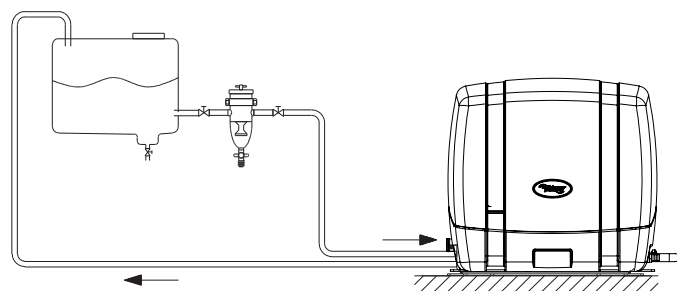

Fig.6: Fuel tank above the genverter

### 2.7.2 Fuel lift pump

All models are fitted with an external fuel lift pump. therefore the tank can be installed at a lower level than the generating set (see Figure 7). The maximum suction height is 0,6 m. The pump should be mounted close to the tank, in an angle or vertically to prevent air bubbles from blocking the system.

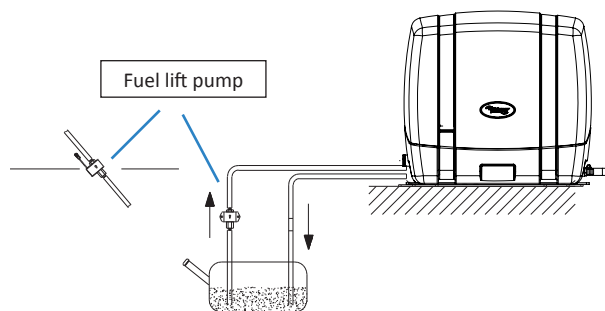

Fig.7: Fuel line assemblies with pump mounted vertically or in an angle

### 2.7.3 Fuel pipes

When the tank is above the genverter (Figure 6) we recommend ending the return line on the top of the tank. When the return is on the top, siphoning of the return line is impossible in case of a leakage. Only the fuel supply line will need to be fitted with a fuel cock. When the tank is below the genverter (Figure 5) we recommend ending the return line on the bottom of the tank below the inlet of the supply line. This will prevent the fuel supply line from being



drained into the tank when the engine is stopped because air cannot enter into the return line, thus avoiding starting trouble.

Both supply and return fuel pipe lines should be made of appropriate material and have an 8 mm inner diameter. The quality of the tubing of fuel pipes may be subject to local regulations depending on the application of the vessel.

The fuel pipes can be connected to the flexible hoses which are on the genverter and are prepared to be fitted to 8 mm pipe. The resulting fuel line complies with CE standards as well as ISO 7840 A2.

It is important to avoid bends in the pipes, as they could trap air bubbles. The return pipe should never be connected to the suction pipe. The return line should be of 8 mm diameter and go straight back via the top to the bottom of the tank. When the return is too narrow, has too many bends and goes back to the bottom of the fuel tank (i.e. bypassing the top), the back-pressure may be too high. This results in irregular running of the engine. When the engine runs irregularly, check if back-pressure is the problem by disconnecting the return line just outside the canopy and draining it in a canister. When the engine runs smooth now, the return piping has to be changed. It could also help to install a second (electrical 12V) fuel lift pump in the supply line to increase the pressure.

#### 2.7.4 Fuel filters

A fine fuel filter is installed which requires maintenance. Whisper-Power recommends installing an extra fuel filter/ water fuel separator near the fuel tank.



**Before starting your genverter for the first time follow the fuel system bleeding procedure in the user's manual**

## 2.8 COOLING

### 2.8.1 General

For cooling a modern engine in a vessel, two methods are available: intercooling and keel cooling. Keel cooling is basically a direct extension of the engine's internal cooling system. Intercooling, on the other hand, is based on a raw water pump, heat exchanger and water-injected exhaust. Cooling liquid in the internal cooling system is cooled in a heat exchanger by outboard water (raw water or seawater). After the raw water is warmed up in the heat exchanger it is dumped overboard by injecting it in the exhaust.

### 2.8.2 The internal cooling system

The internal cooling system should be filled with long-life G12+ cooling liquid. As the engine warms up the liquid expands and the system is pressurized. When the pressure is sufficiently high, the release valve in the filling cap on the manifold opens and the expanding liquid is pressed into the expansion tank that is in the delivery. Also the air in the system that is collected at the top of the manifold is released in this way. When the liquid cools down there will be under-pressure. Another valve opens and the liquid is sucked into the manifold again. This system works only when

there is enough liquid initially.

This has to be checked when commissioning the generator set. By filling up the expansion tank when necessary there will always be enough liquid in the system. The hose that is in the delivery has to be connected to the connection on the side of the filling cap. This is a non-kinking hose made of heat resistant plastic.

The hose passes through a hole in the base.

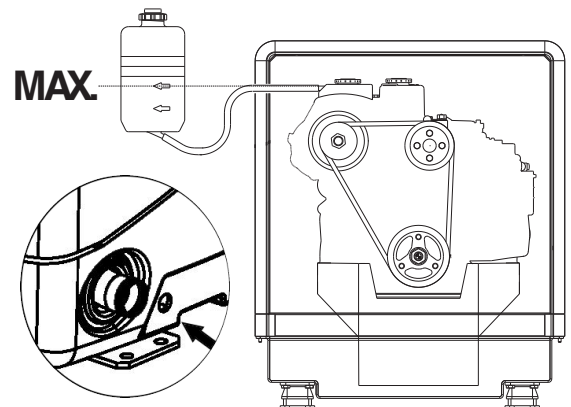

Fig.8: Expansion tank placement

The tank has to be placed close to the generator (see Figure 8). When it is mounted above the top of the manifold the liquid in the tank will be drained when the cap on the manifold is taken off. When keel cooling or radiator cooling is used, the system will not be pressurized and a cap without release valve should be applied.

### 2.8.3 Keel cooling

Keel cooling involves circulating the hot coolant through a space in the keel, through a double walled skin of the boat, through a box cooler, using a big tank or any other external cooler. Keel cooling systems are extensively described in a separate manual (art. no. 40200251). For these particular genverters, only a single external cooler is needed.

### 2.8.4 Intercooling

When applying intercooling the genverter should have its own raw water inlet and should not be connected to any other engine systems. A properly installed cooling system is critical to keep engine temperatures within an acceptable range. Ensure that the installation complies with the following installation instructions.

#### 2.8.4.1 Raw water supply

For raw water supply the following installation materials are required:

- skin fitting
- sea cock
- water strainer
- hoses and clamps

In order to keep the suction resistance in the line at a minimum, the sea water intake system (i.e. sea cock, trough-hull fitting, inlet

filter, etc.) must have an inner diameter matching the genverter's, i.e. at least 19 mm (3/4") or 25 mm (1"), as applicable. The suction hose should be kept as short as possible. Bends should be avoided. Restriction of raw water flow, caused by kinked hoses, undersized pipes or connections will reduce the engine cooling capability. This is the main cause for overheating of an engine.

After running the generating set for the first time, check the coolant flow rate using a stopwatch and by holding a pail of a known volume under the wet-exhaust outlet. The flow rate should be according to the data in the User's Manual.

### 2.8.4.2 Through-hull fitting

It is good practice for yachts to use a hull inlet fitting with an integrated strainer (water scoop). For propulsion engines in motorboats the water scoop is often mounted against the sailing direction to induce more water intake for cooling.



**This should not be done in the case of a generating set! When sailing at higher speeds, water will be forced into the inlet and your generating set will overflow! (see Figure 9).**

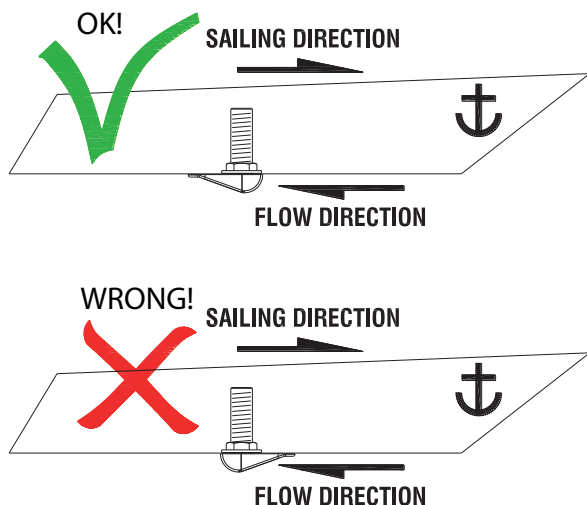

Fig.9: Installing the water intake

On motorboats and on sailing boats the water scoop for a generating set should be fitted with the opening faced backwards to prevent water being forced in during sailing.

### 2.8.4.3 Water strainer

Use an appropriate water strainer with connections of well accessible position, 5 cm above the waterline (see water inlet kit item 7).

### 2.8.4.4 Siphon breaker (air vent)

When the point of water injection is below the waterline, then – when the engine is stopped – there is a risk that the cooling water may enter the engine as a result of siphoning. To avoid this,

the generating set is designed to accommodate a siphon breaker (air vent). In the standard delivery the connections are sealed.

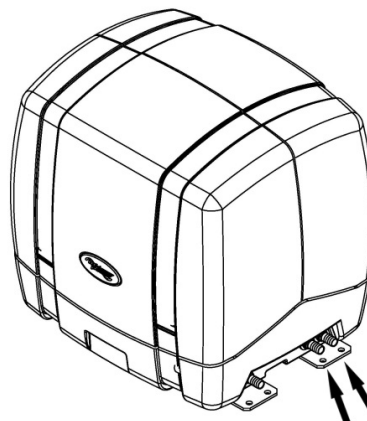

Fig.10: Syphon breaker connections

If the generating set cannot be mounted such that the bottom of the set is above the waterline, an air vent must be installed.

Extend the water hose of the by-pass 60 cm above waterline and install an air vent. Ideally, the air vent should be mounted above the yacht keel centre line (i.e. to minimize the influence of swaying on the water intake). Hose with an inner diameter of 19 mm (1/2") or 25 mm (3/4"), as applicable, should be used.

Fast motorboats will lay deeper when sailing at large speed (non- planing) and have additional pressure on the water inlet. This should be avoided to prevent water from entering into the engine.



**If the air vent is clogged, the water hoses will not be vented when the generating set has stopped and water can be forced into the engine. This leads to immediate engine problems and possibly severe damage!**

**DAMAGE CAUSED BY THE INGRESS OF WATER IN THE ENGINE IS NOT COVERED BY GUARANTEE.**

The siphon breaker that is delivered with the Whisper Power siphon breaker installation kit does not require a connection for a hose to drain the little water that could be spilled from the valve. If you use another kind of siphon breaker that has a hose connection, make sure that the drain should go downwards directly and that it may not end under water (refer to Figure 11).

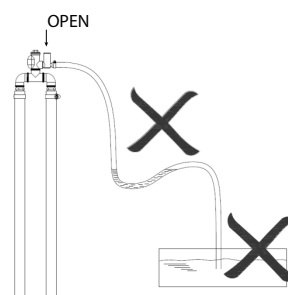

Fig.11: Wrong siphon breaker hose routing (non-WhisperPower siphon breaker)

Water must flow out freely and air has to flow in freely as well. Check the air vent at regular intervals. Open, clean and lubricate the valve as required.

## 2.9 WET EXHAUST SYSTEM

### 2.9.1 General

Water is injected in the exhaust system of the generating set. In this way the cooling water that has passed the heat exchanger is mixed with the exhaust gases. Temperature and volume of the gases are thereby reduced considerably, so that a rubber exhaust hose can be used and the level of noise is reduced as well.

### 2.9.2 Standard exhaust system

The generating set exhaust system must remain completely independent and separate from the exhaust system of any other engine on board. A water lock prevents the generating set from being flooded by cooling water and should be installed as close to the generating set as possible. The lock must be large enough to hold the entire water volume held in the hose from the top of the goose neck to the water lock. The water lock must be installed at the lowest point of the exhaust system (see Figure 12, ref. 1).

The exhaust hose must have an inner diameter of 40 mm (1½"). The exhaust system must be installed so that the back pressure inside the exhaust does not exceed 0,07 bar (1psi – 70 cm water column) and total length from the generator to the top of the goose neck or water/separator does not exceed 3 m (10 ft.).

The exhaust hose descends from the capsule to the water lock. Then the hose rises via the "goose neck" to the through-hull exhaust outlet, situated minimum 50 mm above the water line (Figure 12, ref 5). The "goose neck" must be vertical and situated preferable along the ship's keel centre line. If the generating set is mounted less than 600 mm (24") above the waterline, a "goose neck" must be installed to prevent the engine from overflowing. It is recommended to install an extra muffler (Figure 12, ref 2) close to the through-hull fitting.



**Because of the small gas flow of the small engine, it is very important to keep strictly to the instructions above. Some mufflers and water locks cause too high back pressure. You are advised to use a WhisperPower installation kit or check the back pressure. Too high back pressure causes the system to fill up with water that affects the outlet valve and valve seat.**

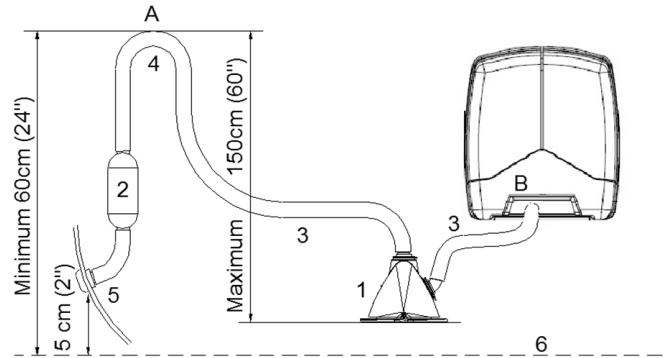

Fig.12: Standard exhaust system

- |                           |  |
|---------------------------|--|
| 1 Exhaust water lock;     | 5 Through-hull exhaust outlet Ø 40 mm; |
| 2 Exhaust outlet muffler; | 6 Water level.                         |
| 3 Exhaust line Ø 40 mm;   |  |
| 4 Goose neck;             |  |

### 2.9.3 Super silent exhaust system

In order to reduce the noise level of the generating set to a minimum, an option to reduce the exhaust noise further (especially exhaust water splashing) is an exhaust/water separator. The exhaust/water separator allows the cooling water to be ejected through a line (Figure 13, ref. A) separate from the exhaust fumes and also functions as a goose neck to prevent water from flooding the engine. If the exhaust/water separator is mounted more than 60 cm above the water level an additional goose neck is not required.

If the through-hull exhaust outlet has to be mounted far from the generating set (i.e. the length of the exhaust piping from the generator to the top of the goose neck (water separator) exceeds 3 m; see Figure 14), an exhaust/water separator must definitely be installed. The sea water from the separator must then run down along the shortest possible path to the through-hull outlet. Only after the exhaust/water separator the exhaust hose may have a length of over 7,5 m (Figure 14).

However, water traps should be avoided as the fumes still contain water and this should not accumulate in bends (see

Figure 15). An additional outlet exhaust muffler close to the hull outlet will help further to reduce noise emission (Figure 12, ref 2).

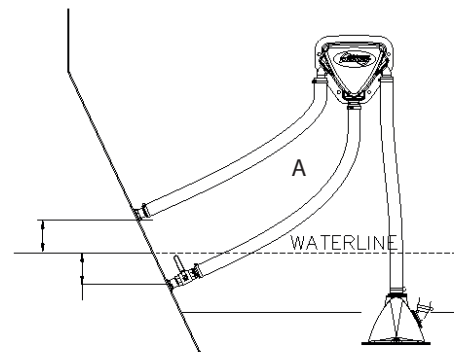

Fig.13: Super silent exhaust system

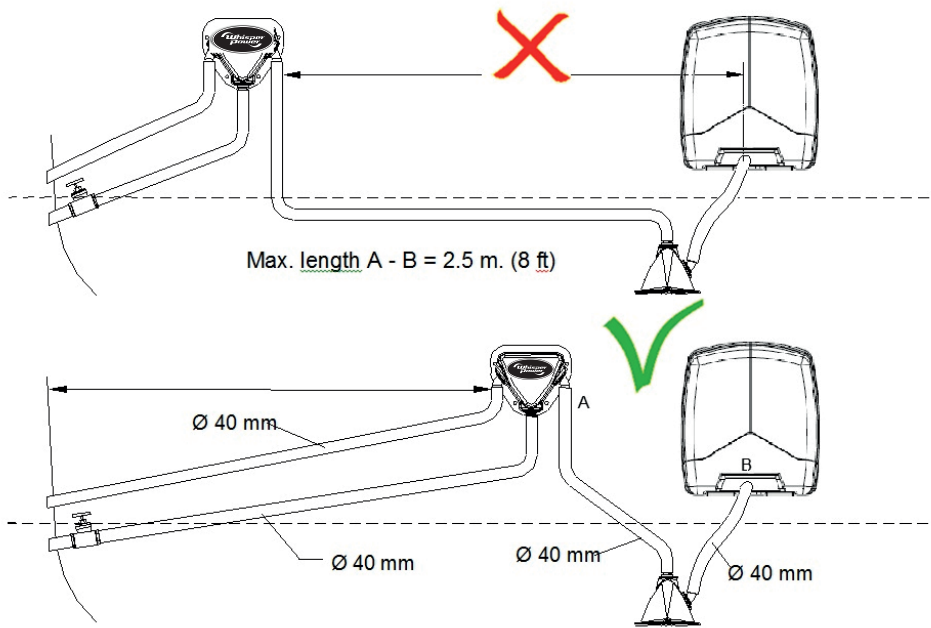

Fig.14: Install the water lock close to the generator (Hoses Piccolo 18 Ø50mm)

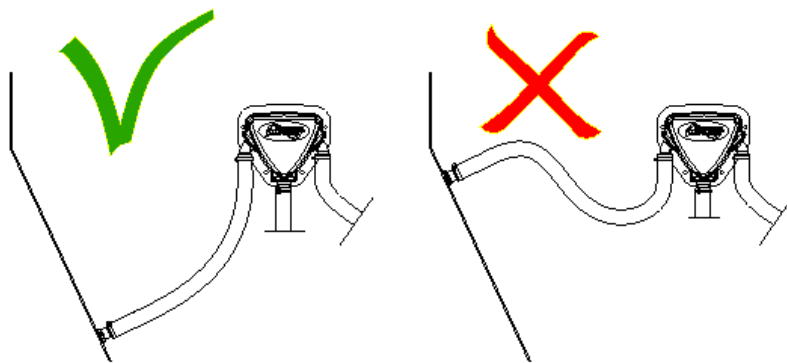

Fig.15: Water trap in exhaust system

When installing the skin passage for the exhaust gas take care that the exhaust gas flow does not touch the water surface. This can cause a lot of noise. (see Figure 16)



**Do not aim the exhaust gas flow directly at the water surface.**

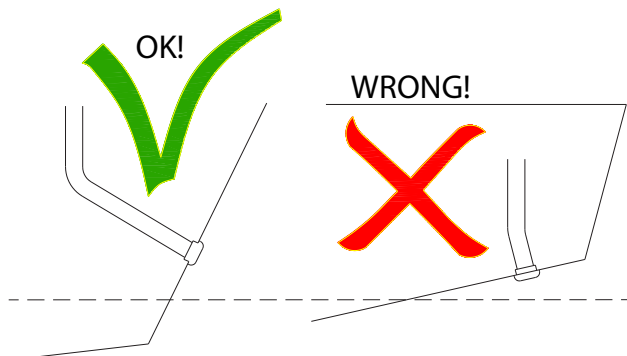

Fig.16: Outlet direction

### 3 ELECTRICAL INSTALLATION

#### 3.1 DIGITAL DIESEL CONTROL SYSTEM

##### 3.1.1 General

The standard electrical control system is in 12 Volt with negative earth. Non-earth return is available as an option. The engine is controlled by a highly advanced microprocessor based system: Digital Diesel Control, which has both a local control and a remote panel.

##### 3.1.2 Remote control

A remote control panel also containing a microprocessor is included in the delivery, as well as a 10 m 8-pole communication cable (Figure 17). Other lengths are available on request. A longer (up to 30 m) cable can be connected if required. For distances exceeding 30 m, please consult the WhisperPower service department.

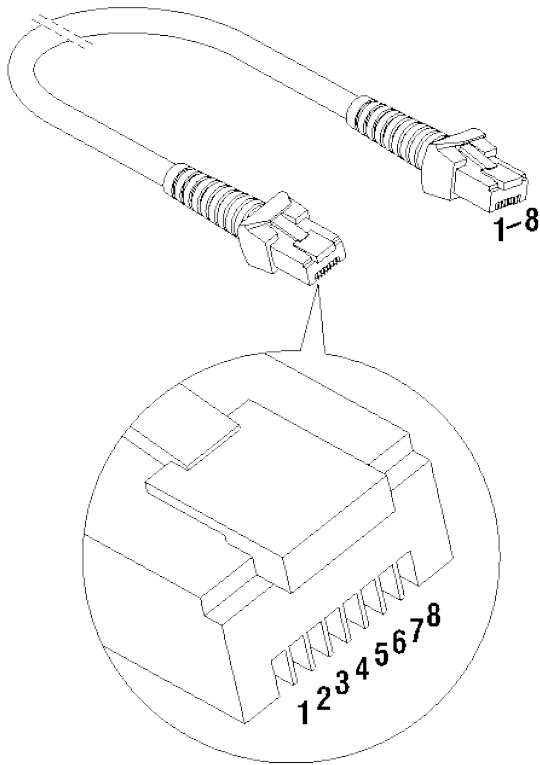

Fig.17: Remote control cable

The control panel can be mounted in the dashboard using the plastic sawing template. For dimensions, refer to the drawings in Chapter 5.

Two more remote control panels (slave panels) can be put in parallel using the modular connectors on the back of the units. Actually, the slaves are regular remote control panels offering all functions again.

When using the factory settings, installation is very simple: just plug in both end of the communication cable and the genverter is ready to use (see Figure 18).

##### 3.1.3 Acoustic alarm or warning lamp

An external max. 150 mA relay can be connected in order to generate an acoustic warning, light a warning lamp, etc. Be aware of polarity as some relays have a diode inside and must be connected positive to positive and negative to negative as indicated (Figure 18).

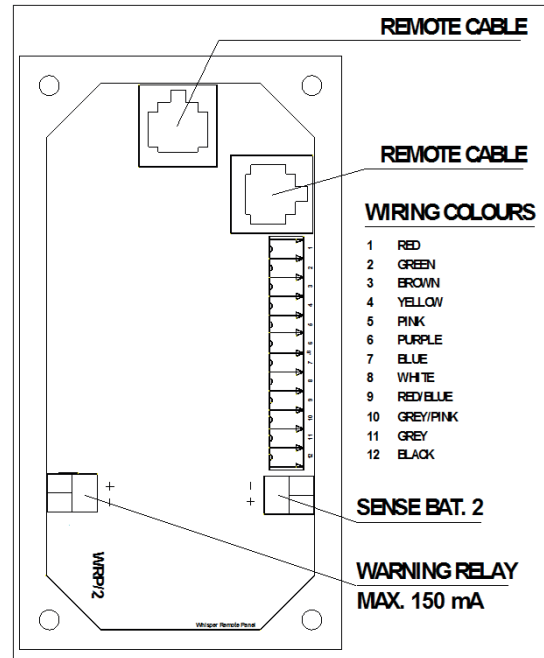

Fig.18: Remote box terminals

##### 3.1.4 Connection for emergency stop / fire alarm switch

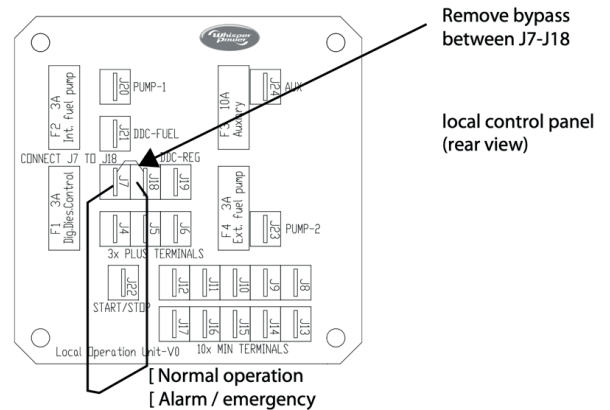

Fig.19: Connection for emergency stop / fire alarm switch

To connect an emergency stop button or to stop the generator automatically in case of a fire alarm, you can use the bypass connection between fastons J7 and J18 on the backside of the local control panel (Figure 19). To do so, remove this bypass connection and then replace it by an emergency switch or a potential free fire alarm switch with normally closed contacts.

### 3.1.5 Automatic starting and stopping

#### 3.1.6 General



WhisperPower cannot be held responsible for damage caused by the genverter running unattended using the auto-start/stop mode or interval mode



Using the auto-start/stop or interval mode, the genverter may start unexpectedly. When working on the electrical system, the 3 Amp fuse must be removed from the control panel and the battery plus cable must be removed from the battery



Included in the delivery are warning stickers to be applied on several parts of the electric installation (transfer switch, distribution box, etc.) to warn against possible automatic starting of the genverter.

The WhisperPower Digital Diesel Control system offers several options for automatic starting and stopping. This menu as well as other DDC menus may be locked. For unlocking and setting these options, refer to the APPENDIX of the DDC user’s manual.

#### 3.1.7 Start/stop by external switch

At the back of the DDC remote control panel (40209102), you will have the possibility to connect two wires in order to allow the genverter being started by an external signal. This requires the optional 12-pole green connector (part no. 50209119).

Two common options are shown in Figure 20, where the signal can be provided by an external relay or by the Whisper Battery Monitor (WBM).

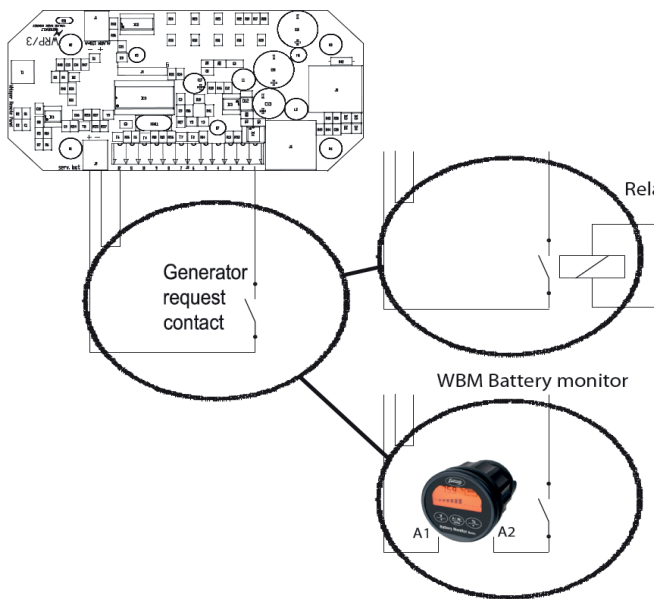

Fig.20: Connection for start/stop by external signal

Another possibility is to monitor the voltage of a second battery (not being the starter battery) and to start the genverter automatically when this voltage drops below a set value. This second battery is often called “auxiliary battery” or “service battery”. It is referred to as BAT2 in the DDC menus. A sense wire to monitor the second battery should be connected (check polarity!) to the connector on the back of the remote panel (Figure 18). The sense wires must be connected directly to the second battery and be protected by a 3A fuse

**Settings:** For settings other than the factory settings, refer to the DDC user’s manual, especially to the APPENDIX.

#### 3.1.8 STARTER BATTERY

For starting, the genverter requires a 12V starter battery of 80 Ah.

The genverter can be connected to the main engine battery or have its own battery. We strongly recommend the use of a separate battery for the genverter and keeping the wiring system for the main engine and the domestic DC supply system completely separate and individually connected to separate batteries.

However, the negatives of all batteries on the vessel should be interconnected in order to prevent differences in earth voltage levels on different places, which might cause trouble to electronic devices in the system.

The above recommendation is not valid for vessels having the starter battery of the main engine or other auxiliary equipment positive grounded. When this is the case an expert should be consulted.

A battery switch may be used to interrupt the positive connection.

The starter battery is charged by the alternator on the engine. An additional battery charger will help to keep the battery in good condition when the genverter is not used.(see Figure 21)

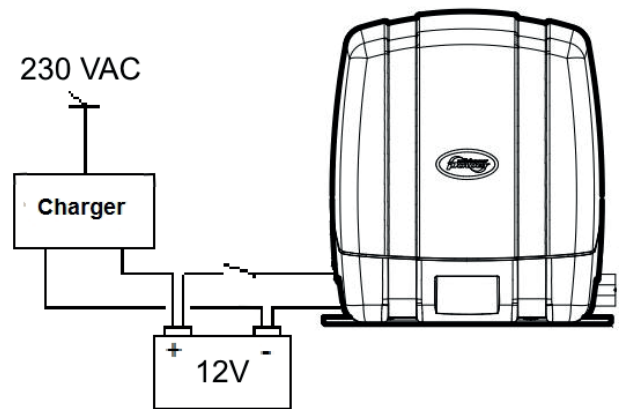

Fig.21: Starter battery

### 3.2 OTHER RECOMMENDATIONS AND WARNINGS

The battery should be secured for rough sea conditions and the terminals should be insulated. For extra safety the battery can be enclosed in a wooden, plastic, fiberglass etc. (non metal) box. Even when the earth return system is applied a negative battery cable should be used and the vessel should not to be used as a conductor.

The battery cables are supplied in a standard length of 1.5 m. If longer cables are required a larger cross sectional area should be considered to compensate for voltage reduction.



**When two batteries are used in series to provide a 24 Volt supply system, never take off 12 Volt (starting) power from one of these batteries. This will result in severe damage to both batteries within a short timer**

Disconnect the battery leads if electrical welding is to be carried out, otherwise damage will be caused to the diodes of the alternator



**As explosive hydrogen gases may be discharged during charging, the battery should be located in a well-ventilated space. Ensure that the supplied battery cable connectors are properly fitted. Never remove these during or shortly after charging, as sparking may occur, igniting the hydrogen gases.**

### 3.3 ALTERNATING CURRENT



#### DANGER

**The electric power supplied by the genverter is of a high voltage and dangerous to people. Before working on the system read the sections on safety in the users manual.**



**Generators used on vessels that are operated in a hazardous environment often have to fulfil special regulations and additional measures have to be taken accordingly**

These genverters are designed to generate power for both AC and DC installations, depending on the type of WhisperPower PowerCube or Power Module installed with the genverter. Be sure that all electrical installations (including all safety systems) comply with all regulations required by the local authorities. All electrical safety/shutdown and circuit breaking systems have to be installed on-board as the genverter itself cannot be equipped with such equipment for every possible variation.

The vessel's power supply system should be suitable and safe for the voltages applied and the power that will be generated. Special attention has to be paid on dividing the system in branches which are fused individually.

It is absolutely essential that each and every circuit in the electrical system be properly installed by a qualified electrician.

### 3.4 CABLE PROTECTION (FUSES)

It is the installer's responsibility to protect the live wires between the genverter and the PMG/DC PowerCube. Check the electrical information on the identification plate in order to calculate the right fuse size.

Please note that the above is in addition to any fuses required between the PMG/DC PowerCube and the AC installation or batteries, as applicable.

### 3.5 GROUNDING

The AC alternator windings are not grounded.

The housing of the alternator and all other metal parts are grounded.

The electric installation in the vessel needs to be protected against insulation failures. Methods of protection are subject to rules that may differ depending on the use of the vessel and local standards. Experts in this field should be consulted.

Be aware that insulation protection systems can be different for different applications and even within the ship there could be different standards for different spaces. Sometimes other standards shall be complied with, e.g. for certification societies such as Lloyd's Register of Shipping or Veritas, regulations for the protection of personnel, building legislation, etc. It is of the greatest importance to have expert advice on this issue.

For safety reasons connect the main ships ground to the negative of the generating set start battery. However, when a ungrounded DC system or positive grounded DC system is applied the battery negative should not be connected to the main ships ground.

### 3.6 CABLE

For the power cable we recommend the use of 3 wire oil resistant cable with a sufficient cross sectional area. For long cables it is recommended to apply cables with a larger cross section (refer to ISO 13297, Annex A).

## 4 INSTALLATION SUMMARY

### 4.1 GENERAL

- 1 Mount the genverter directly, without additional vibration dampers, on a solid surface.
- 2 Connect cooling system.
- 3 Connect exhaust system.
- 4 Connect 'fuel supply line' to the water separator/ fuel filter.
- 5 Connect 'fuel return line' to the fuel tank.
- 6 Connect remote panel (just plug in).
- 7 Connect the AC cables to the PMG/DC PowerCube.
- 8 Connect the battery cables to the 12V starter battery positive and negative terminals.
- 9 Install a WhisperPower battery charger (optional).

### 4.2 COMMISSIONING TABLE

- 1 Check if the air inlet is sufficient.
- 2 Check if the cooling system for the engine is properly installed and properly filled with G12+ cooling liquid .
- 3 Check if the exhaust system is properly installed. Check maximum length of exhaust hose, diameter of exhaust piping.
- 4 Check all coolant connections.
- 5 Check the AC cables and the grounding.
- 6 If the genverter is installed with a WP-PMG, check if an AC breaker is installed before or after the power source selector. When there is only a circuit breaker, use it to disconnect the generating set from the grid.
- 7 Check all DC connections, check if the battery switch/ circuit breaker is closed.
- 8 Open the fuel valve. Check if there are no air leaks in the fuel supply line, and check if the lift of the fuel is less than 1 m. Check if there is no air in the water-fuel separator.
- 9 Check if the air intake in the canopy is not blocked.
- 10 Check the oil level and colour of the oil.
- 11 To bleed the fuel system, push the "Start" button on the local control (not on the remote panel) and hold at least 5 s and as long as necessary to bleed the system.
- 12 Start the engine by pushing the start button.

- 13 If the genverter is installed with a WP-PMG, check the delay of 5 to 10 seconds in the power source selector transfer.
- 14 Check voltage under 'no load' conditions.
- 15 Check if the genverter can bring the full load.
- 16 Check if the battery charger of the genverter is working (max. 14.5 V).
- 17 Close the sound shield and check the noise level.
- 18 Stop the genverter and check the engine again for leakages of oil, fuel or coolant and check the oil level again.

### 4.3 TECHNICAL DATA

Refer to the User's Manual for an overview of general technical specifications.

### 4.4 SPECIFICATION OF THE ACCESSORIES

Item	Size on Piccolo 8 and Piccolo 10	Size on Piccolo1 8
Water pickup scoop	1/2" = 19 mm	1/2" = 19 mm
Inlet valve	1/2" in / 19 mm out	1/2" in / 19 mm out
Water strainer	19 mm in / 19 mm out	19 mm in / 19 mm out
Air vent	19 mm	19 mm
Inlet suction hose	19 mm	19 mm
Fuel filter/water separator	30 micron	30 micron
Fuel inlet and return	8 mm	8 mm
Exhaust hose	Ø 40 mm inner	Ø 50 mm inner
Water lock	Ø 40 mm	Ø 50 mm
Water/gas separator	Ø 40 mm	Ø 50 mm



### 4.5 INSTALLATION MATERIALS

#### WATER INLET KIT

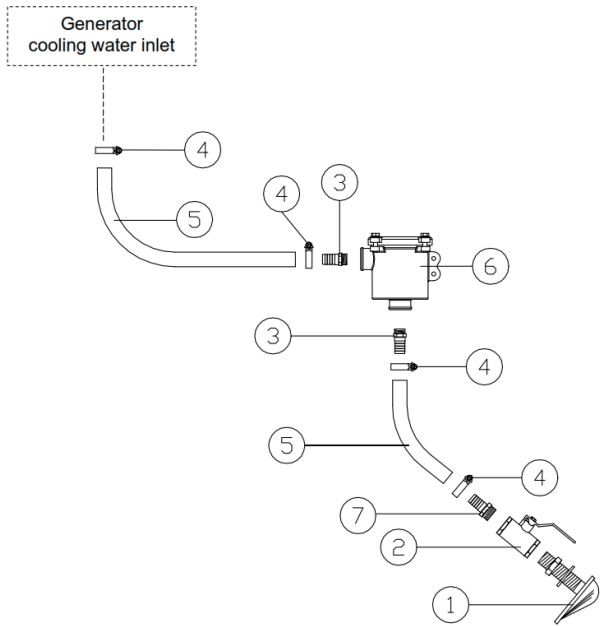

Number	Quantity	Article no	Description	Dimensions
1	1	50230052	Water pickup scoop	¾"
2	1	50230042	Lever operated ball valve f/f	¾"
3	1	50221004	Male hose connector	¾" × 20 mm
4	4	50221503	Hose clamp, stainless	19-29 mm
5	3	50220056	Raw water hose	19x28 mm
6	1	50230060	Nickel plated brass intake strainer	½"
7	2	50221007	Male hose connector	½" × 20 mm
<b>TOTAL</b>		<b>40230211</b>	<b>WATER INLET KIT 20 mm (1/2")</b>	

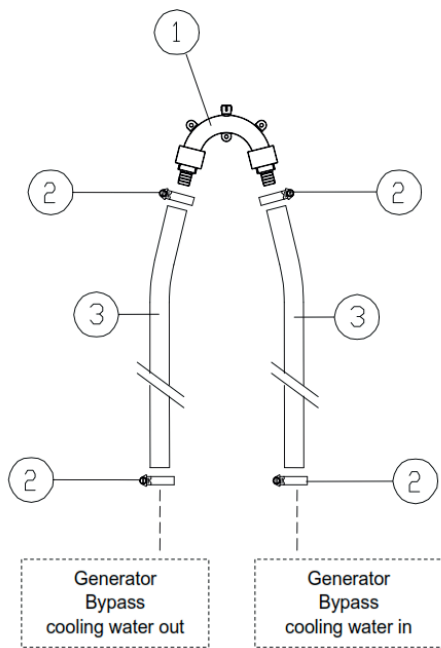

Number	Quantity	Article no	Description	Dimensions
1	1	50230019	Syphon breaker (including valve assembly)	20 mm
2	4	50221502	Hose clamp	19-29 mm
3	3 m	50220056	Raw water hose	19 × 28 mm
<b>TOTAL</b>		<b>40230273</b>	<b>SYPHON BREAKER KIT 20 mm (¾")</b>	

**WATER SEPARATOR AND WET EXHAUST KITS (40 mm)**

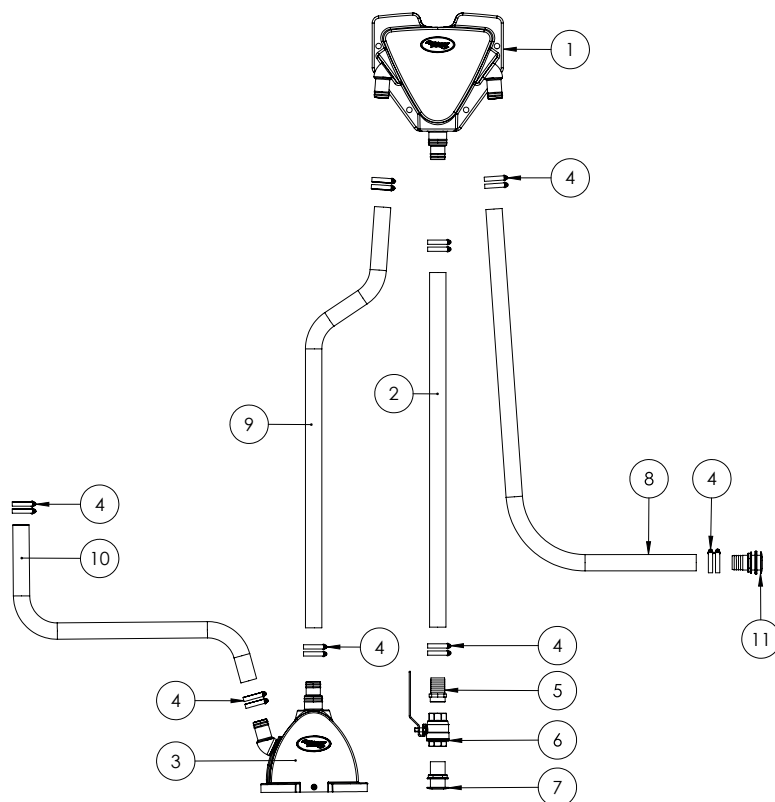

According to ABYC recommendations all hose connections should be made using double clamps. Maximum torque for hose clamps: 6.0Nm

Number	Quantity	Article no	Description	Dimensions
11	1	50230038	Brass through hull fitting hose connection	1 1-4 x 40
10	1	50220033	Marine exhaust hose	40 mm (1 5-8 inch)
9	1	50220033	Marine exhaust hose	40 mm (1 5-8 inch)
8	1	50220033	Marine exhaust hose	40 mm (1 5-8 inch)
7	1	50230033	Brass through hull fitting	1 1-4 x 70
6	1	50230044	Lever operated ball valve FF	1 1-4
5	1	50221015	Hose grommet External thread	1 1/4"x 40
4	16	50221504	Hose Clamp RVS 32- 50	32- 50
3	1	40230083	WP-WL 40-40 Waterlock	40-40
2	1	50220033	Marine exhaust hose 40 mm (1 5-8 inch)	40 mm (1 5-8 inch)
1	1	40230087	Water Gas Separator Assy 40/40/40	40-40-40
		<b>Article no</b>		
<b>Contents of the delivery</b>		40230281 (Waterlock kit 40mm)	Pos 4 (8x), 10 & 8 (Total 3m), 3 (1x), 11 (1x)	
<b>Optional installation materials</b>		40230291 (Total Delta/gas separator kit 40mm)	Pos 1 (1x), 4 (8x), 9 & 2 (2.5m), 5 (1x), 6 (1x), 7 (1x)	

**WATER SEPARATOR AND WET EXHAUST KITS (51 mm)**

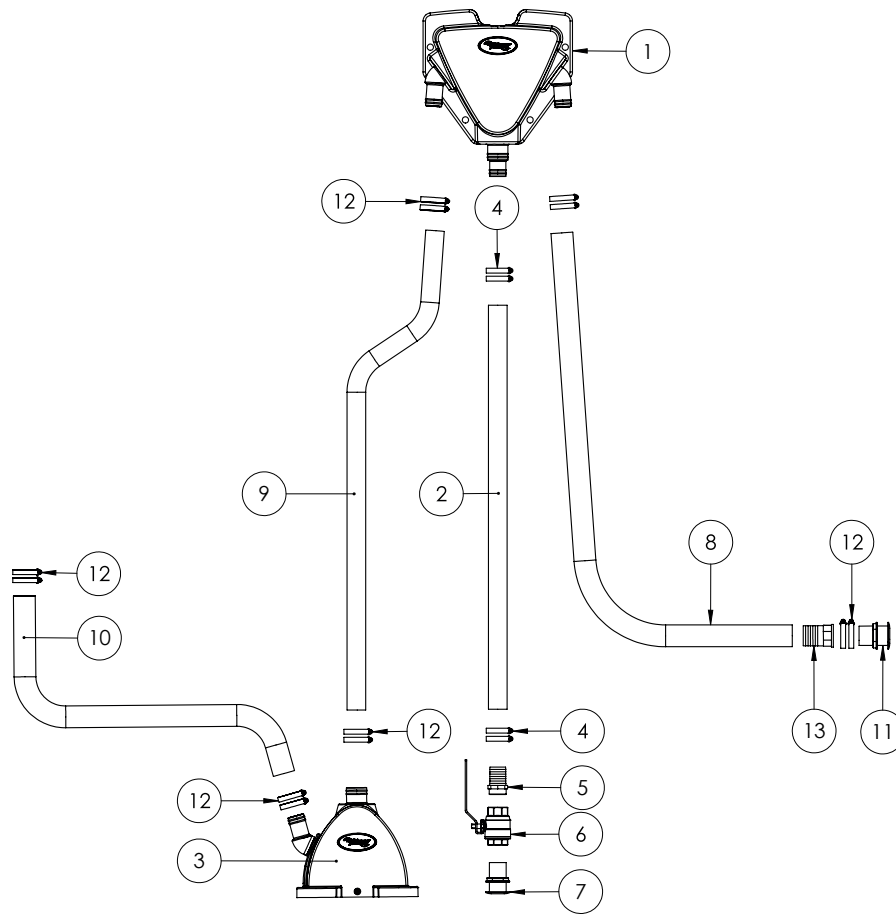

According to ABYC recommendations all hose connections should be made using double clamps. Maximum torque hose clamps: 6.0Nm / 54 InLbs

Number	Quantity	Article no	Description	Dimensions
13	1	50221024	Female hose connection	1 1/2 x 50
12	12	50221505	Hose Clamp RVS	40- 60
11	1	50230034	Brass through hull fitting	1 1/2 x 50
10	1	50220035	Marine exhaust hose	51 mm
9	1	50220035	Marine exhaust hose	51 mm (1 5-8 inch)
8	1	50220035	Marine exhaust hose	51 mm
7	1	50230033	Brass through hull fitting	1 1/4 x 70
6	1	50230044	Lever operated ball valve FF	1 1/4
5	1	50221015	Hose grommet External thread	1 1/4"x 40
4	4	50221504	Hose Clamp RVS	32- 50
3	1	40230084	WP-WL Waterlock	51-51
2	1	50220033	Marine exhaust hose	40 mm (1 5-8 inch)
1	1	40230088	Water Gas Separator Assy	51-40-51
		<b>Article no</b>		
<b>Contents of the delivery</b>		40230292 (Total Delta/gas separator kit 51mm)	Pos 1 (1x), 4 (4x), 12 (4x) 9 (2,5m), 2 (2.5m), 5 (1x), 6 (1x), 6 (1x),7 (1x)	
<b>Optional installation materials</b>		40230282 (Waterlock kit 51 mm)	Pos 12 (8x), 10 & 8 (Total 3m), 3 (1x), 11 (1x), 13 (1x)	

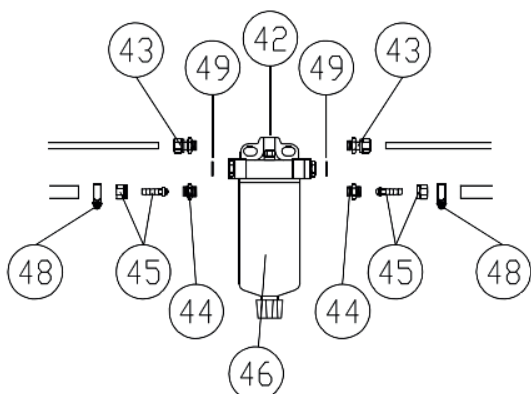
**FUEL KIT**

Number	Quantity	Article no	Description	Dimensions
42	1	50230091	Filter head for fuel strainer/water separator	M14x1.5 mm
43	2	50221618	Parallel male coupling	M14- 8 mm
44	2	50221619	Parallel male coupling	M14- 10 mm
45	2	50221620	Hose connection, outer cone	M16 × 1.5 mm, 8 mm
46		50230092	Filter for fuel strainer/water separator	
48	4	50221522	Hose clamp, stainless	10-16 mm
49	2	50221632	Gasket ring	18 × 14 × 1.5 mm
not shown	2	50221203	Straight coupling	8 mm
not shown	2	50221252	Barbed-smooth hose nipple	8 mm
TOTAL		40230205	FUEL KIT	

**OPTIONAL INSTALLATION MATERIALS**

Number	Quantity	Article no	Description	Dimensions
48	1	50221522	Hose clamp, stainless	10-16 mm
not shown	per m	50222020	copper fuel pipe	6 × 8 mm
not shown	per m	50220063	fuel hose	8 × 16 mm

**BATTERY INSTALLATION KIT**

Article no	Description	Dimensions
61112002	WBC-Handy 20 charger 12V / 2A	157 × 33 × 34 mm
40290093	battery terminal (NEG-)	
40290094	battery terminal (POS+)	
40290099	M8 battery pole adapter set	
40290098	isolation caps (red & black)	
502144701	WP-Compact Manual Battery Switch, 300A	72 × 72 × 78 mm
40290106	INSTALLATION KIT FOR BATTERIES UP TO 100 Ah	

**RECOMMENDED BATTERIES**

Article no	Description	Dimensions
40290061	AGM-Power 12V 80Ah Absorbed Glass Matt	350 × 167 × 180 mm

# 5 DIAGRAMS & DRAWINGS

## 5.1 ELECTRICAL DIAGRAMS

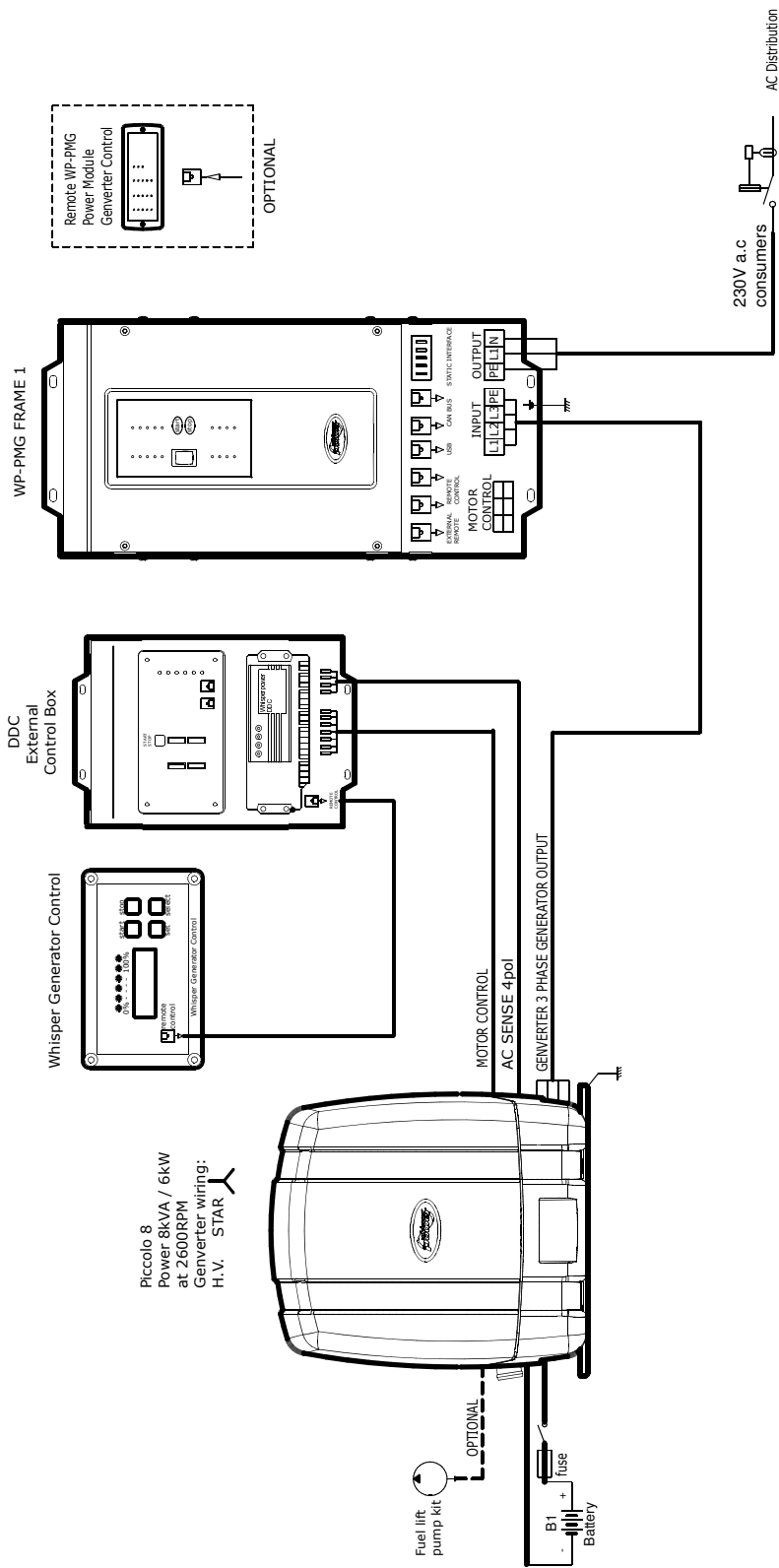

Symbol	Configuration
	Earth
	Earth frame
	Normal open isolating switch
	Fuse
	Cross over without connection
	Connected branch circuit

TITLE Design Review	WP Piccolo 8 + DDC Model WP-PMG Frame 1 Single Line Diagram
DATE 20/06/2018	SHEET NUMBER A2
DRAWN BY M. S.	PROJECT REF. 950031.003
CHECKED BY M. S.	ARTICLE NO. 950031.003
REVISION B	REVISION B

Fig.22: Layout of Piccolo 8 genverter system





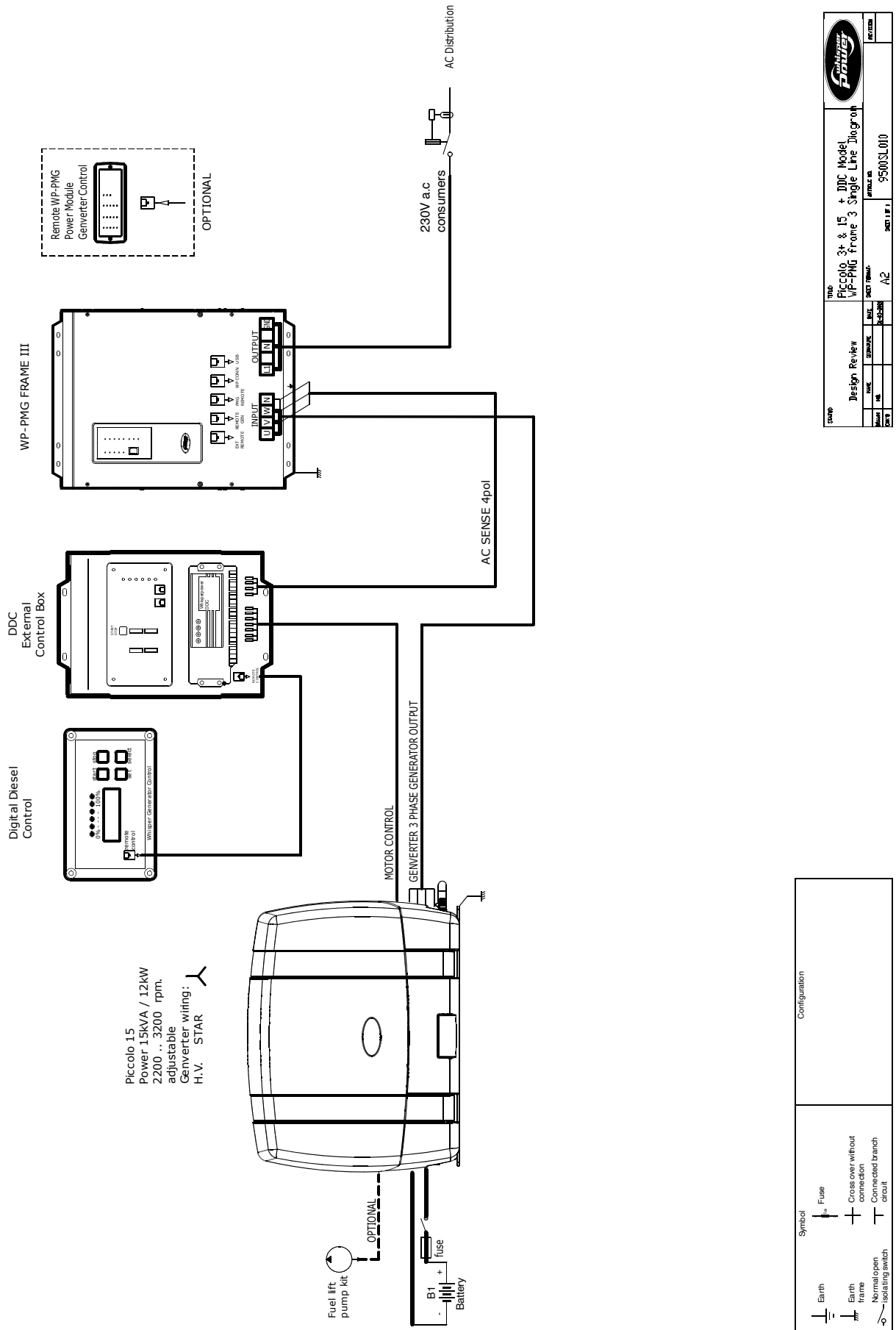

Fig.25: Layout of Piccolo 3, 15 Genverter system.



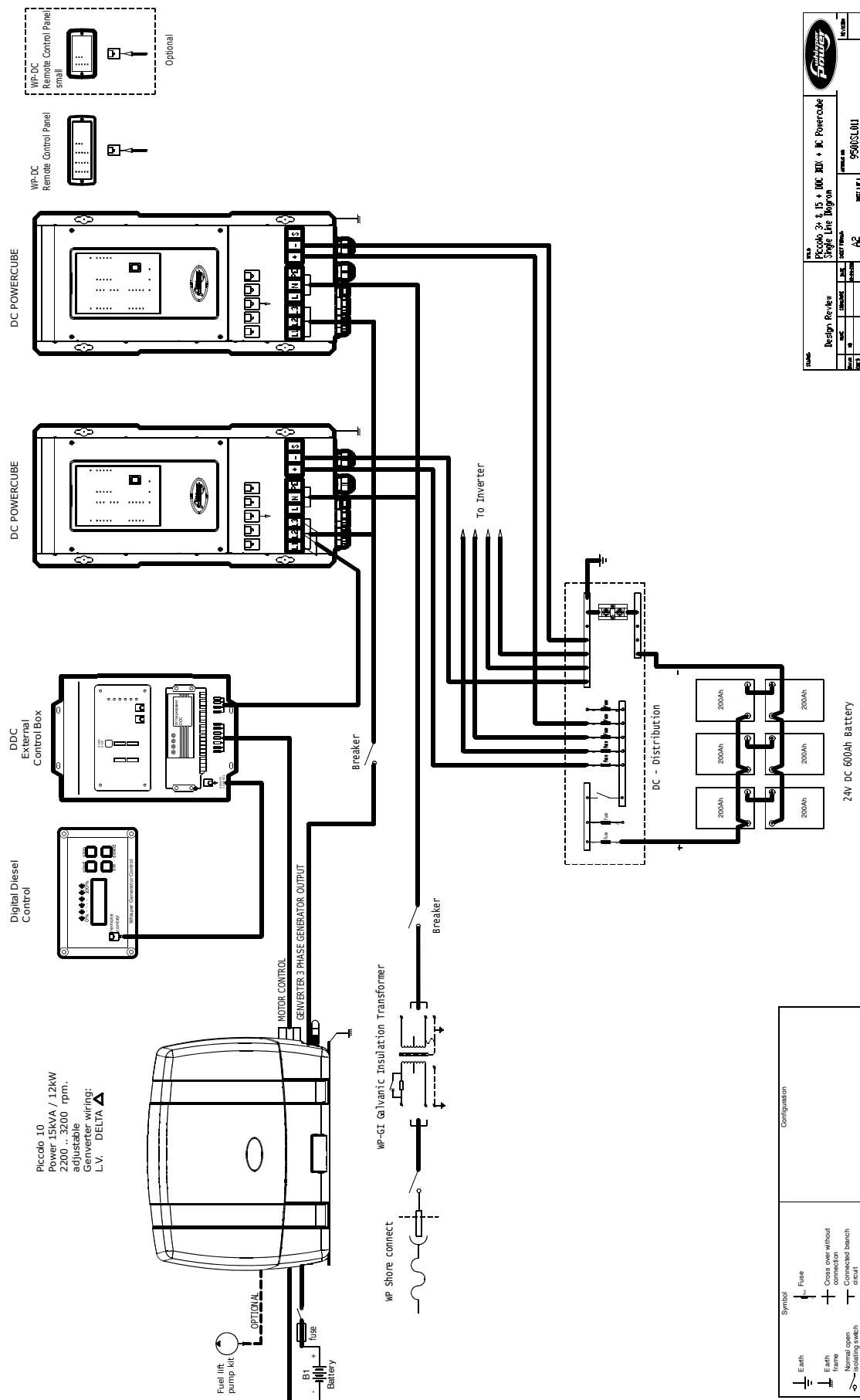
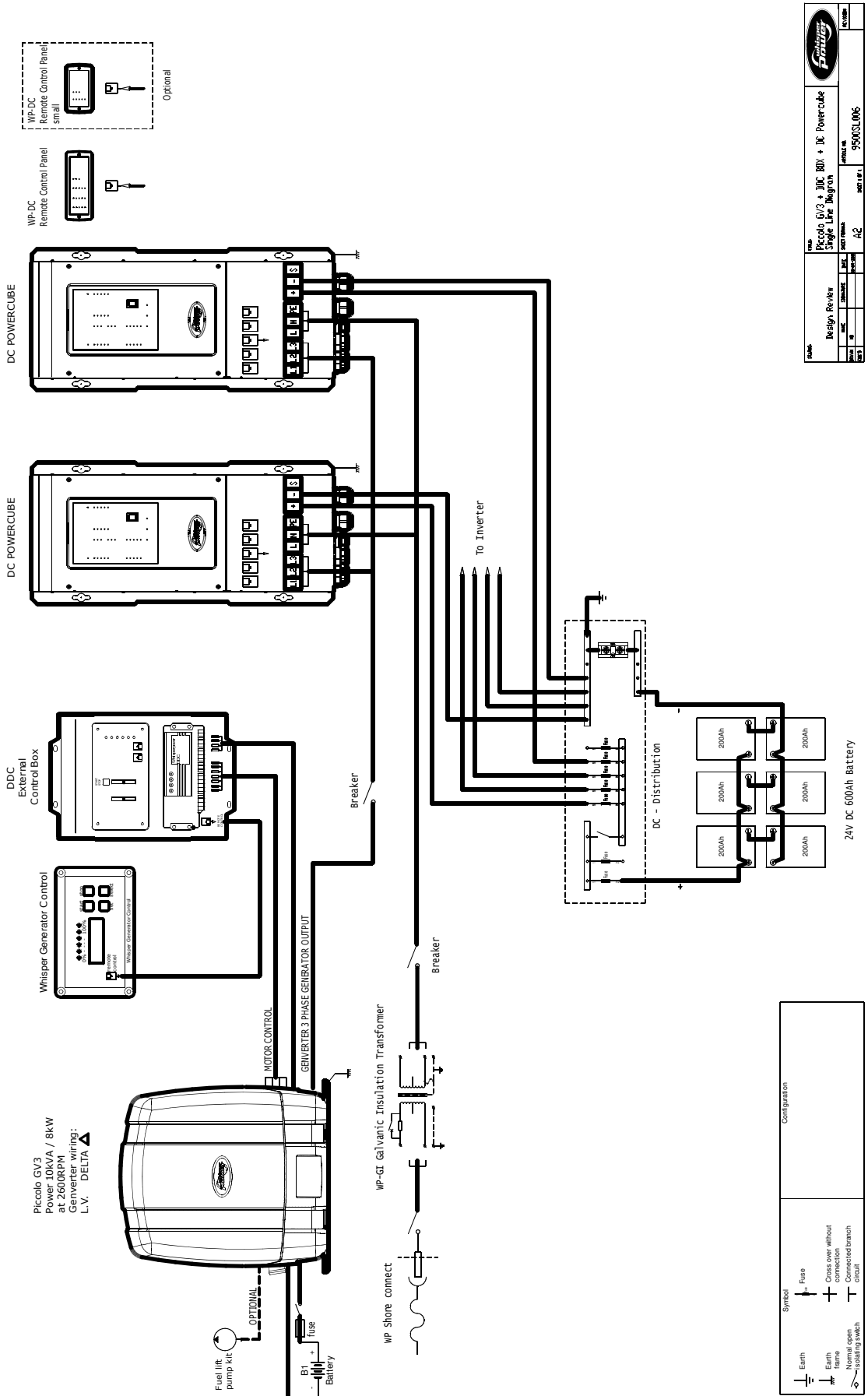
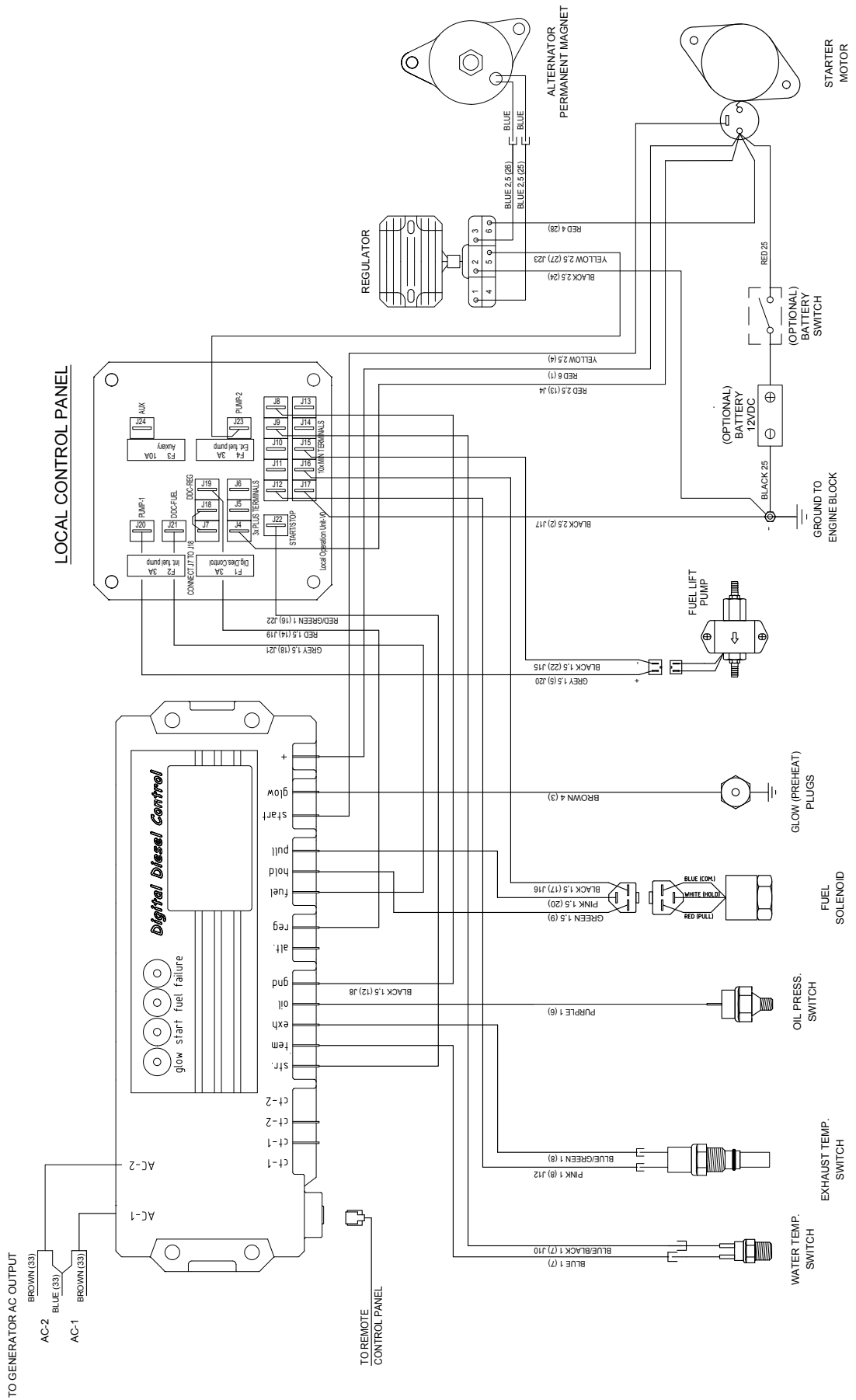

Fig.26: Layout of DC generator system featuring Piccolo 10 and two DC PowerCubes



Model: <b>Piccolo GV3 + JMC + DC Powercube Stroke Line Inverter</b>	Part No: <b>9500SL006</b>
Design Review:	AC:
Date:	Rev:
Drawn:	Checked:
Approved:	Date:

Fig.27: Layout of DC generator system featuring Piccolo 3 and two DC PowerCubes



Name <b>7013CD150001</b>	Description: Layout DDC GV-2 Kubota		
	Checked	Drawn by F.B.	
	Plot/datum	Date 05/08/2015	
	RevisionNumber A	Revision 05/08/2015	
	PROJECTNUMBER 7015 GV-2 Kubota		
	SUBPROJECT		
	ALL SHEETS 1	SHEET 1	
	PREV 1	NEXT 1	

Whisper power

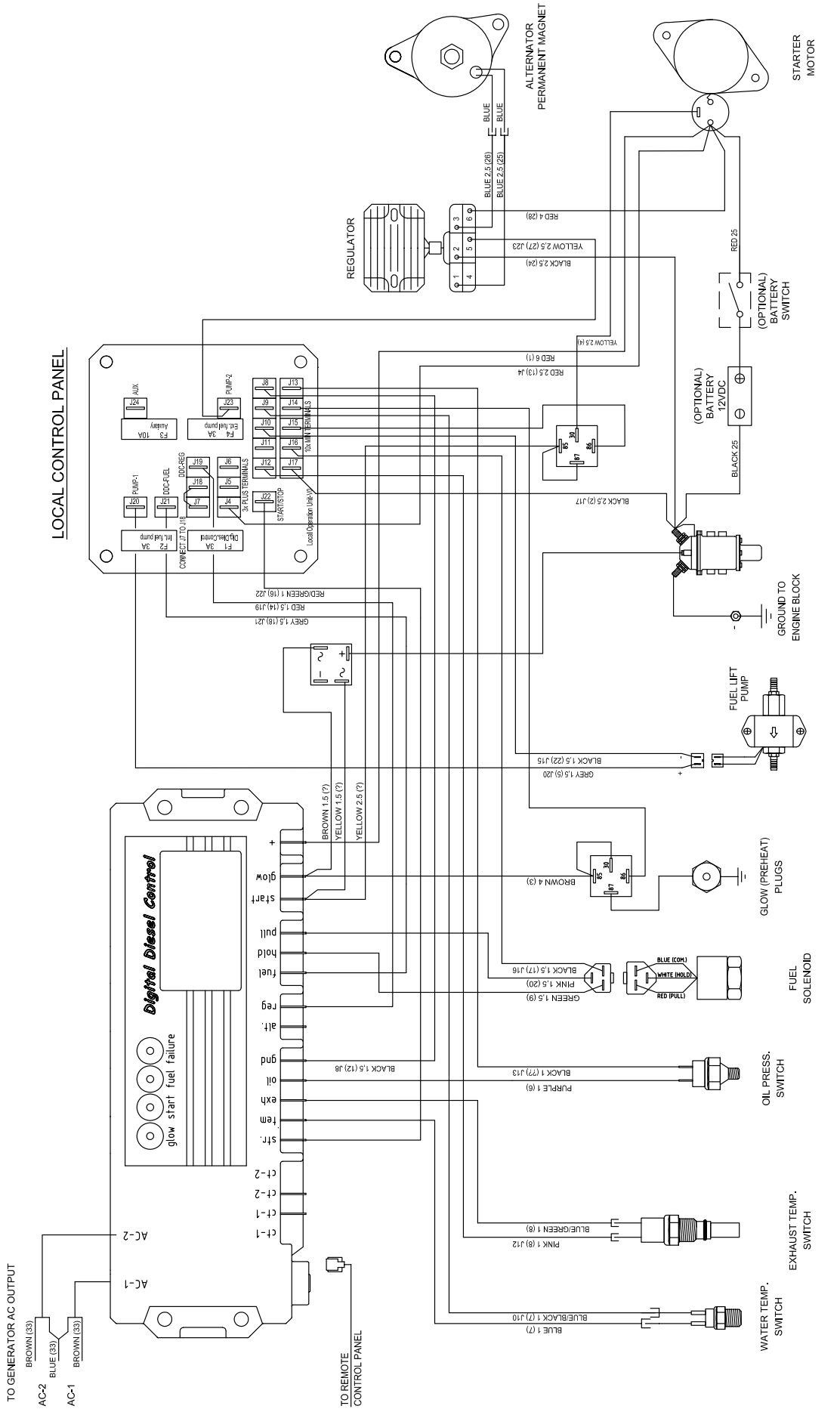

**LOCAL CONTROL PANEL**

Name 7013 GV-2 Kubota Massa Vrij		PROJECT NUMBER 70130501011 Layout DDC GV-2 Kubota Massa Vrij	
Description: CONNECTION DIAGRAM		Revision 14/10/2015	Revision Letter C
SUBPROJECT		PREV 1	NEXT 1
Checked	Plotdatum 01/09/2015	ALL SHEETS 1	
Drawn by AJJK	Date 01/09/2015	SHEET 1	

**Whisper power**

## 5.2 MECHANICAL DRAWINGS

- 1 Exhaust Marine:  $\phi 40$  hose connection
- 2 To expansion tank
- 3 AC Power 4G4
- 4 AC Sense 4G2.5
- 5 Water in (cold) hose 20 mm
- 6 Fuel out 8mm
- 7 Fuel in 8mm
- 8 Battery + "Red" 25mm<sup>2</sup>
- 9 Battery - "Black" 25mm<sup>2</sup>
- 10 Syphon in/out 20 mm
- 11 Air Filter housing
- 12 Fuel line injector
- 13 Fuel injection pump
- 14 Oil Filler cap
- 15 Thermostat cover

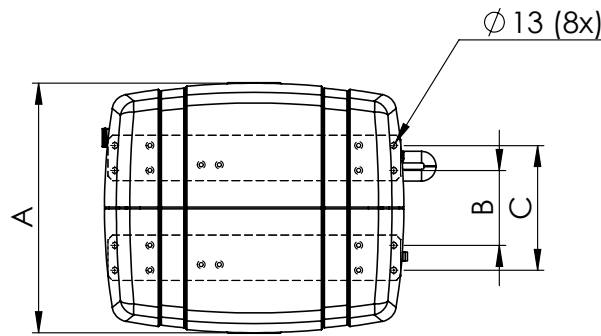

- 16 V-belt
  - 17 Accelerator
  - 18 Stop solenoid
  - 19 Oil dipstick
  - 20 Oil Filter
  - 21 Dynamo
  - 22 Temperature sensor
  - 23 Coolant Filler cap
  - 24 Manifold
  - 25 Exhaust
  - 26 Starter Motor
  - 27 Alternator
- A. 550 mm  
B. 165 mm  
C. 275 mm  
D. 622 mm  
E. 660 mm  
F. 615 mm  
G. 645 mm

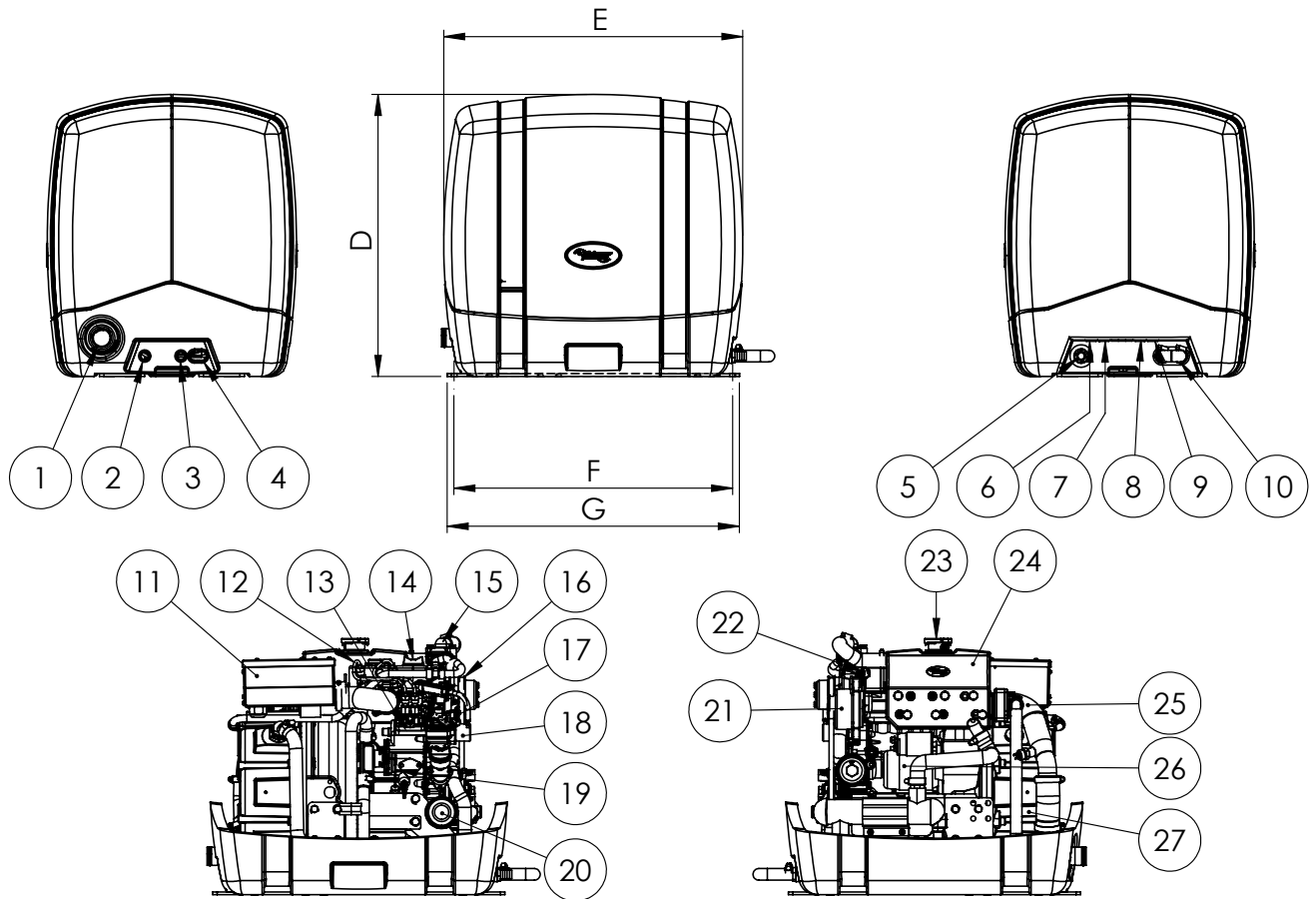

UNLESS OTHERWISE SPECIFIED: CHAMFER SHARP EDGES GENERAL TOLERANCE NEN ISO 2768-m FORM AND PLACE TOLERANCES NEN-ISO 1101 WELDING SYMBOL NEN EN 22553 ROUGHNESS ACC. to NEN3634		TOLERANCE PRINCIPLE ISO 8015		FINISH: -	DO NOT SCALE DRAWING	
PROJECTION : THIRD ANGLE UNITS : mm				Material:	SHEET FORMAT: <b>A4</b>	
STATUS: Date Revision					TITLE: <b>Piccolo 2 + 8</b>	
DRAWN	M.B.	SIGNATURE	DATE	7036A184284	ARTICLE NO. <b>49005005</b>	REVISION
CHK'D	M.B.		16-10-2017			
			26-04-2018			
PRINTED			10-6-2020			
Weight: 175789.84 gram					SCALE:1:14	SHEET 3 OF 4

Fig.28: Piccolo 2/8 dimensions

- 1 Exhaust Marine:  $\phi 40$  hose connection
- 2 To expansion tank
- 3 AC Power 4G4
- 4 AC Sense 4G2.5
- 5 Water in (cold) hose 20 mm
- 6 Fuel out 8mm
- 7 Fuel in 8mm
- 8 Battery + "Red" 25mm<sup>2</sup>
- 9 Battery - "Black" 25mm<sup>2</sup>
- 10 Syphon in/out 20 mm
- 11 Air Filter housing
- 12 Fuel line injector
- 13 Fuel injection pump
- 14 Oil Filler cap
- 15 Thermostat cover

- 16 V-belt
- 17 Accelerator
- 18 Stop solenoid
- 19 Oil dipstick
- 20 Oil Filter
- 21 Dynamo
- 22 Temperature sensor
- 23 Coolant Filler cap
- 24 Manifold
- 25 Exhaust
- 26 Starter Motor
- 27 Alternator

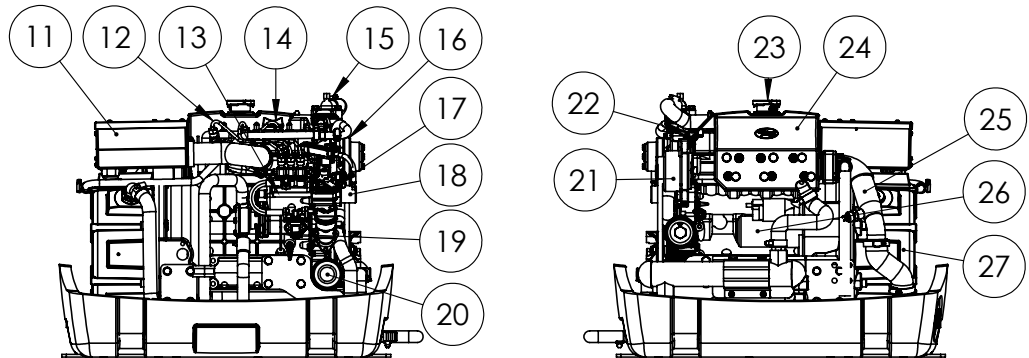
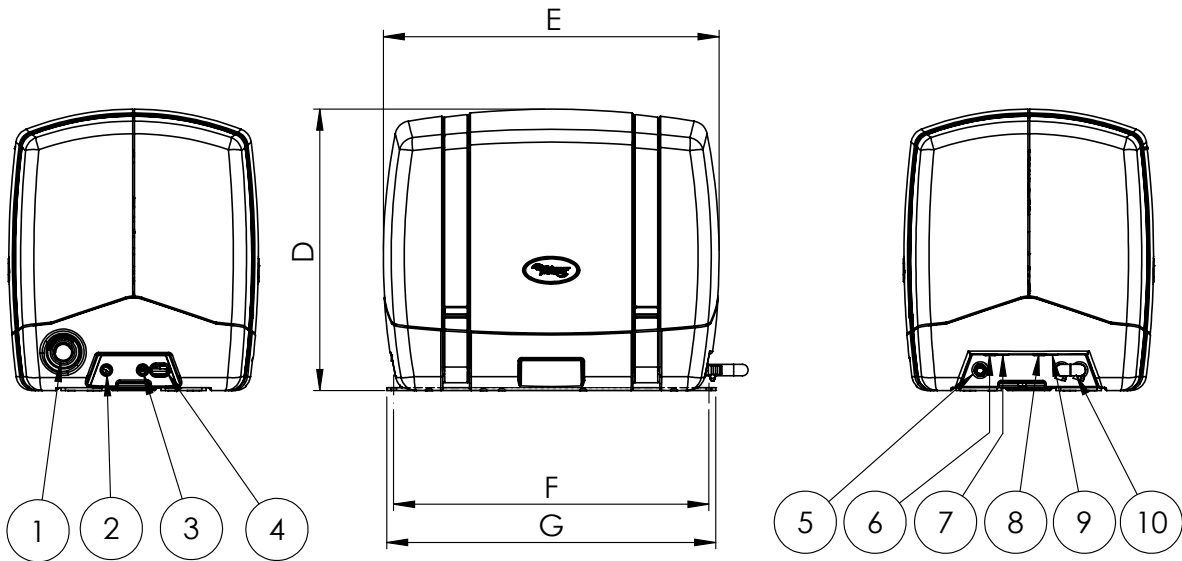
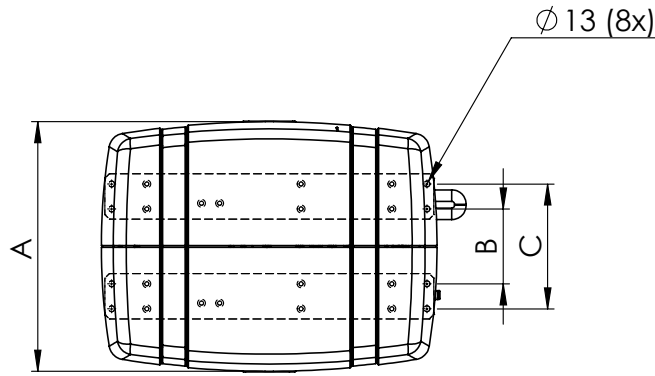

UNLESS OTHERWISE SPECIFIED: CHAMFER SHARP EDGES GENERAL TOLERANCE NEN ISO 2768-m FORM AND PLACE TOLERANCES NEN-ISO 1101 WELDING SYMBOL NEN EN 22553 ROUGHNESS ACC. to NEN3634		TOLERANCE PRINCIPLE ISO 8015		FINISH: -	DO NOT SCALE DRAWING	
PROJECTION : THIRD ANGLE UNITS : mm		Material:		SHEET FORMAT: <b>A4</b>	TITLE: <b>Piccolo 3 + 10 + 12</b>	
NAME	SIGNATURE	DATE	STATUS:	ARTICLE NO. <b>NOT_REQUIRED</b>		
DRAWN M.B.		16-10-2017	Released			
CHKD M.F.		2-4-2020	DRAWING:	REVISION		
			7037A184624			
PRINTED		10-6-2020				

Fig.29: Piccolo 3/10/12 dimensions

- 1 Exhaust Marine: ø40 hose connection
- 2 To expansion tank
- 3 AC Power 5G6
- 4 AC Sense 4G2.5
- 5 Water in hose 20 mm
- 6 Fuel out 8mm
- 7 Fuel in 8mm
- 8 Battery + "Red" 25mm<sup>2</sup>
- 9 Battery - "Black" 25mm<sup>2</sup>
- 10 Syphon in/out 20 mm
- 11 Air Filter housing
- 12 Fuel line injector
- 13 Fuel injection pump
- 14 Oil Filler cap
- 15 Thermostat cover

- 16 V-belt
  - 17 Accelerator
  - 18 Stop solenoid
  - 19 Oil dipstick
  - 20 Oil Filter
  - 21 Dynamo
  - 22 Temperature sensor
  - 23 Coolant Filler cap
  - 24 Manifold
  - 25 Exhaust
  - 26 Starter Motor
  - 27 Alternator
- A. 570 mm  
 B. 225 mm  
 C. 335 mm  
 D. 690 mm  
 E. 882 mm  
 F. 815 mm  
 G. 845 mm

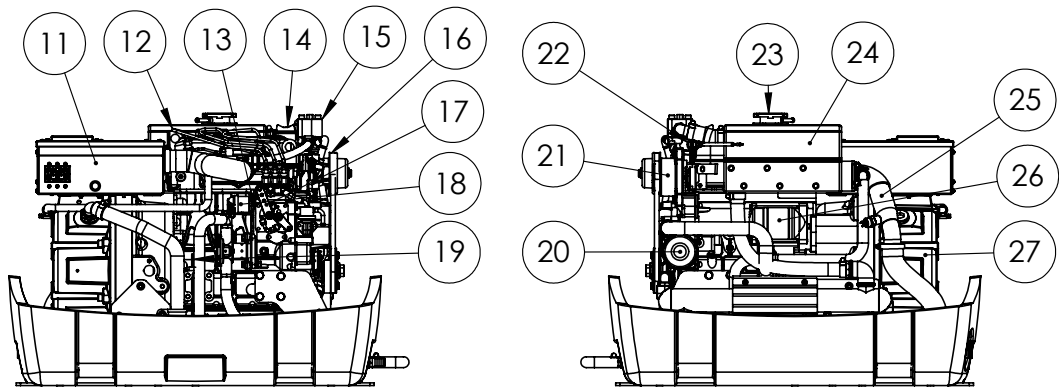
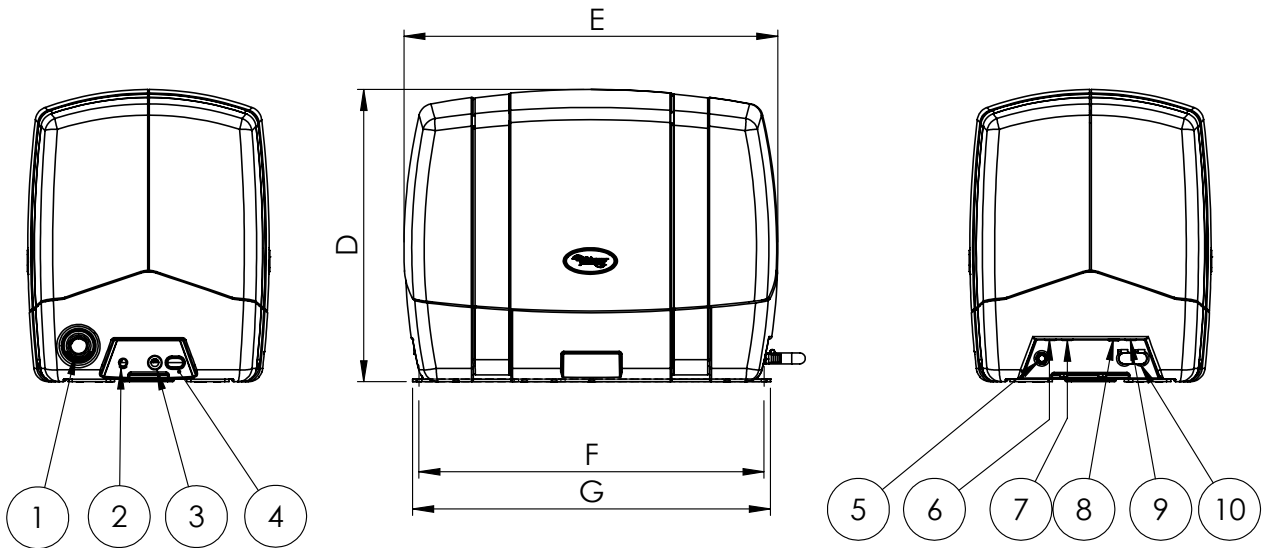
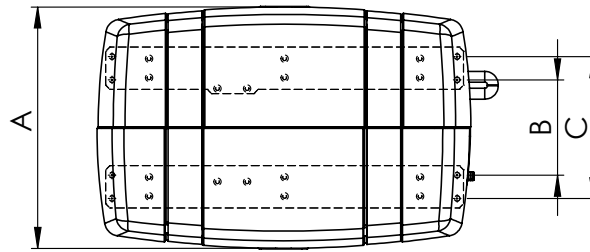

UNLESS OTHERWISE SPECIFIED: CHAMFER SHARP EDGES GENERAL TOLERANCE NEN ISO 2768-m FORM AND PLACE TOLERANCES NEN-ISO 1101 WELDING SYMBOL NEN EN 22553 ROUGHNESS ACC. to NEN3634		TOLERANCE PRINCIPLE ISO 8015		FINISH: -	DO NOT SCALE DRAWING	
		PROJECTION : THIRD ANGLE UNITS : mm		Material:	SHEET FORMAT: <b>A4</b>	
					TITLE: <b>WP_Piccolo 15kVA-3cyl</b>	
NAME	SIGNATURE	DATE	STATUS: <b>Released</b>		ARTICLE NO. <b>NOT_REQUIRED</b>	
DRAWN M.B.		16-10-2017			REVISION	
CHK'D M.B.		31-03-2020				
PRINTED		11-6-2020	DRAWING: 7042A195357			

Fig.30: Piccolo 15 dimensions

5.3

- 1 Fuel out 8mm
- 2 Water IN (cold) hose 20mm
- 3 Fuel IN 8mm
- 4 Syphon in/out 20mm
- 5 Exhaust Marine:  $\varnothing 50$  hose connection
- 6 Battery + "Red" 25mm<sup>2</sup>
- 7 Battery - "Black" 25mm<sup>2</sup>
- 8 To expansion tank
- 9 AC Power 4G6
- 10 AC Sense 4G2.5
- 11 Air Filter housing
- 12 Fuel line injector
- 13 Fuel injection pump
- 14 Oil filter cap
- 15 Thermostat cover

- 16 V-belt
- 17 Accelerator
- 18 Stop solenoid
- 19 Oil dipstick
- 20 Oil filter
- 21 Dynamo
- 22 Temperatur sensor
- 23 Coolant Filler cap
- 24 Manifold
- 25 Exhaust
- 26 Starter Motor
- 27 Alternator

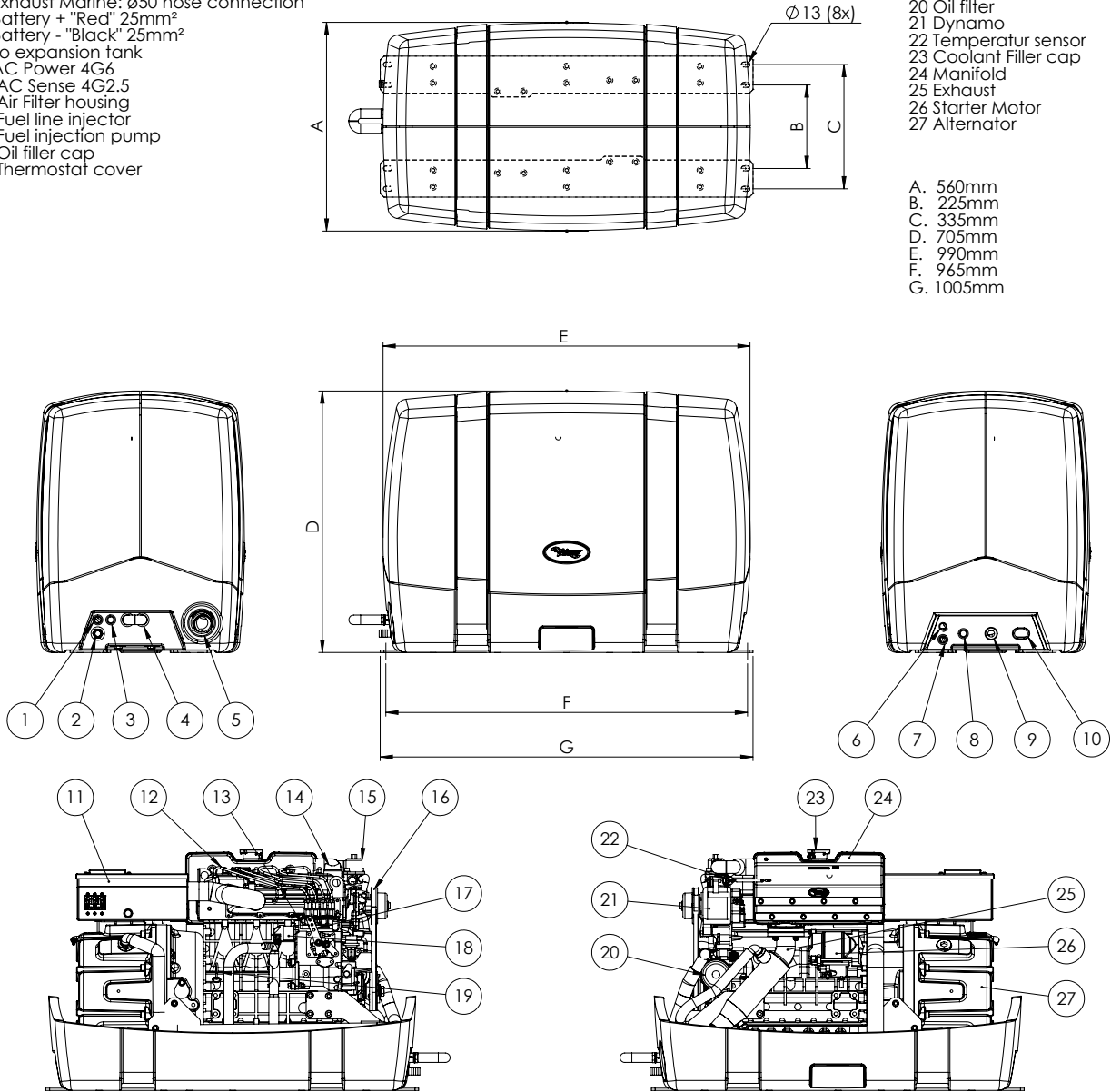

Fig.31: Piccolo 18 dimensions











Enjoy Green Energy

**WhisperPower BV**

Kelvinlaan 82,  
9207 JB Drachten  
The Netherlands

[www.whisperpower.com](http://www.whisperpower.com)  
[sales@whisperpower.com](mailto:sales@whisperpower.com)