

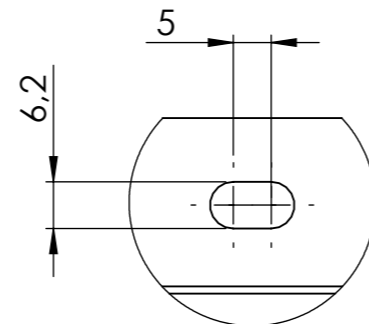

scale 1:5

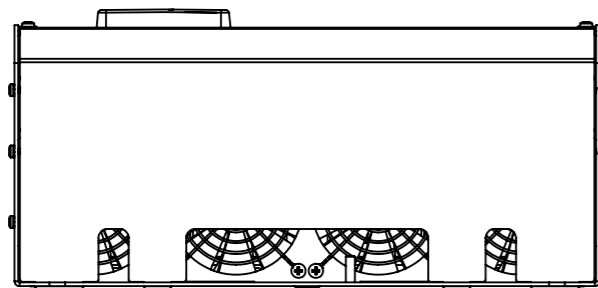

DETAIL A
SCALE 1:1

UNLESS OTHERWISE SPECIFIED: CHAMFER SHARP EDGES GENERAL TOLERANCE NEN ISO 2768-m FORM AND PLACE TOLERANCES NEN-ISO 1101 WELDING SYMBOL NEN EN 22553 ROUGHNESS ACC. to NEN3634		TOLERANCE PRINCIPLE ISO 8015		FINISH: -		DO NOT SCALE DRAWING																
PROJECTION : THIRD ANGLE UNITS : mm				Material:		SHEET FORMAT: A3																
<table border="1"> <thead> <tr> <th>NAME</th> <th>SIGNATURE</th> <th>DATE</th> <th>STATUS:</th> </tr> </thead> <tbody> <tr> <td>DRAWN</td> <td>M.B.</td> <td>18-2-2015</td> <td rowspan="2">Design</td> </tr> <tr> <td>CHK'D</td> <td>M.F.</td> <td>29-04-2014</td> </tr> <tr> <td>PRINTED</td> <td></td> <td>18-6-2015</td> <td></td> </tr> </tbody> </table>				NAME	SIGNATURE	DATE	STATUS:	DRAWN	M.B.	18-2-2015	Design	CHK'D	M.F.	29-04-2014	PRINTED		18-6-2015		DRAWING: 6030A152730		TITLE: WP-PMG 15kW 230V-50Hz Frame 3	
NAME	SIGNATURE	DATE	STATUS:																			
DRAWN	M.B.	18-2-2015	Design																			
CHK'D	M.F.	29-04-2014																				
PRINTED		18-6-2015																				
Weight: 9900.00 gram				SCALE:1:5		ARTICLE NO. -		REVISION														
						SHEET 1 OF 2																

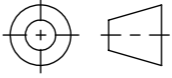
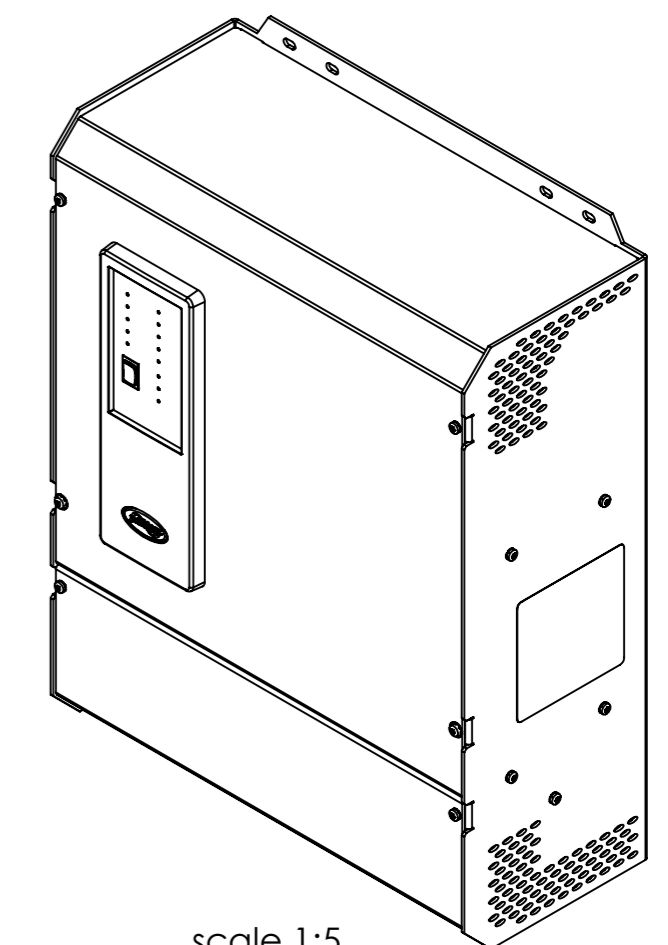
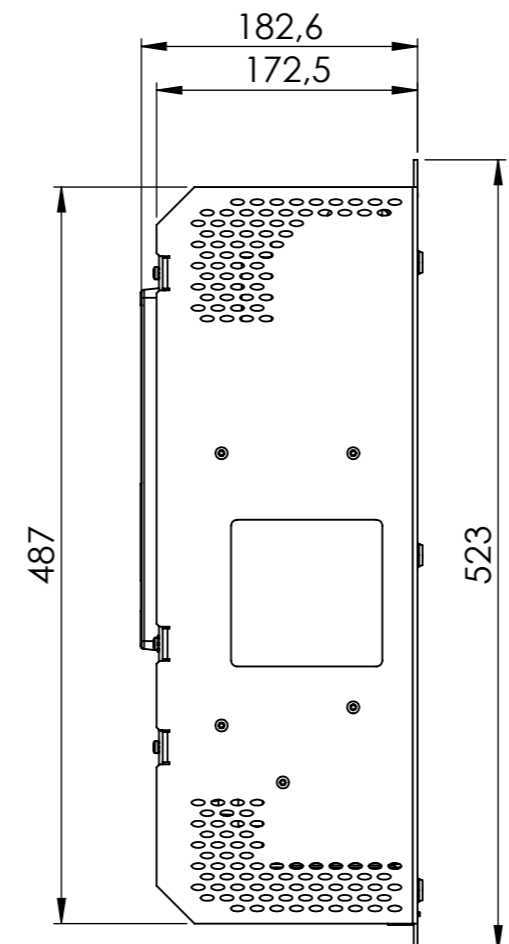
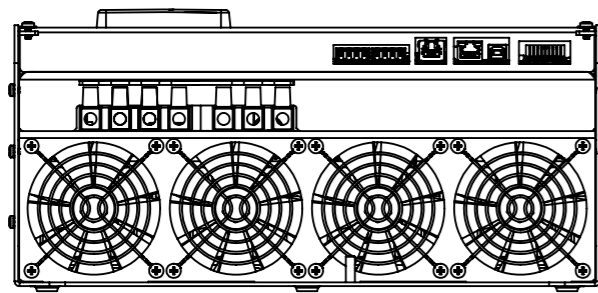
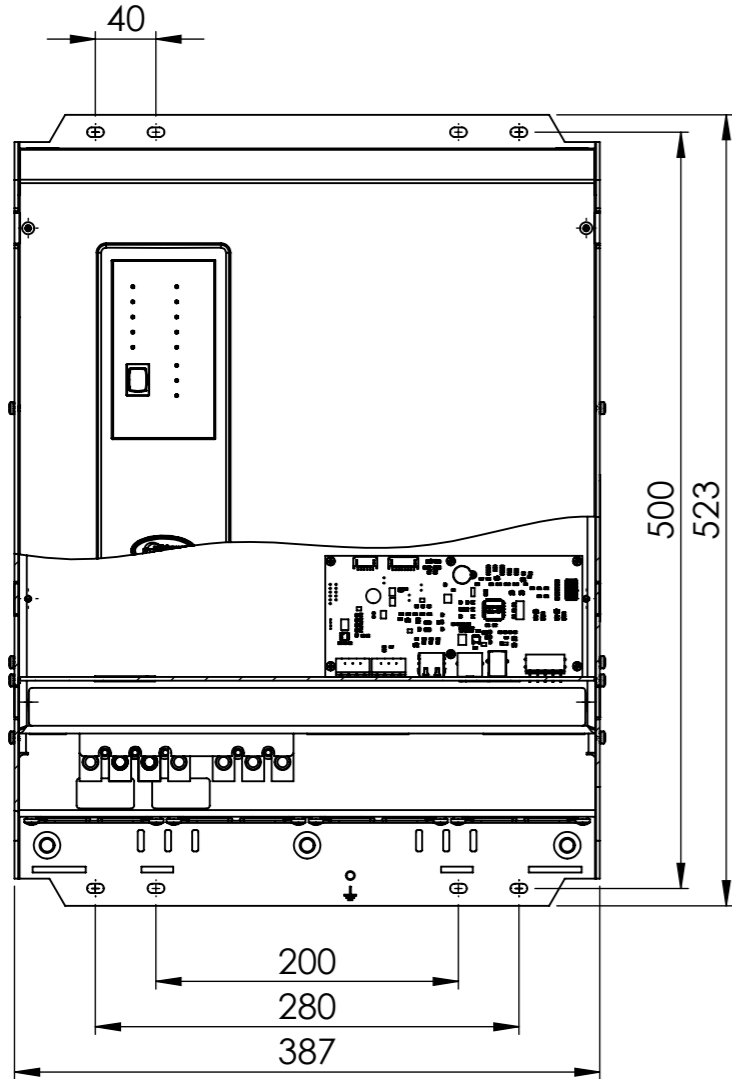
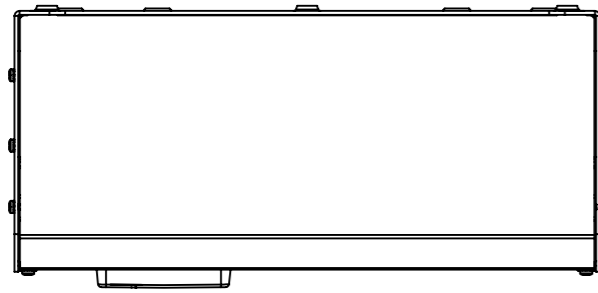

scale 1:5

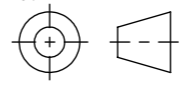
UNLESS OTHERWISE SPECIFIED: CHAMFER SHARP EDGES GENERAL TOLERANCE NEN ISO 2768-m FORM AND PLACE TOLERANCES NEN-ISO 1101 WELDING SYMBOL NEN EN 22553 ROUGHNESS ACC. to NEN3634				TOLERANCE PRINCIPLE ISO 8015		FINISH: -		DO NOT SCALE DRAWING		
				PROJECTION : THIRD ANGLE UNITS : mm		Material:		SHEET FORMAT: A3		
								TITLE: WP-PMG 15kW 230V-50Hz Frame 3		
	NAME	SIGNATURE	DATE	STATUS: Design				ARTICLE NO. -		REVISION
DRAWN	M.B.		18-2-2015							
CHK'D	M.F.		29-04-2014							
PRINTED			18-6-2015			DRAWING: 6030A152730				
				Weight: 9900.00 gram		SCALE:1:5		SHEET 2 OF 2		