

# Installation Manual

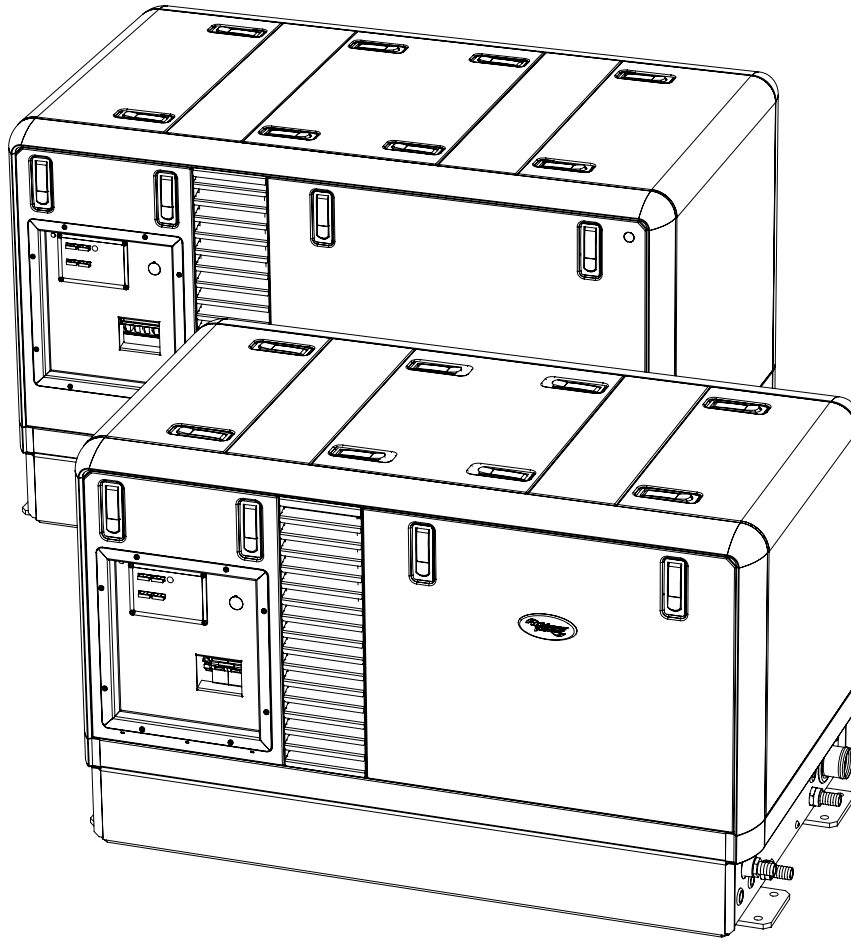

## Marine Diesel Generator M-SQ Pro

15 kVA | 18 kVA | 1500 RPM | 240/120 V | 60Hz | Split Phase

[whisperpower.com](http://whisperpower.com)



## Contents

<b>1</b>	<b>INTRODUCTION.....</b>	<b>4</b>
1.1	General.....	4
1.2	Location.....	4
1.3	Instructions for optimal sound and vibration insulation.....	4
1.3.1	Further recommendations.....	4
1.4	Ventilation.....	4
1.5	Connections.....	5
1.5.1	Fuel supply.....	6
1.5.2	Cooling.....	7
1.5.3	Exhaust system.....	9
1.5.4	Digital Diesel Control system (12 Volt).....	11
1.5.5	AC power system (230 / 400 Volt).....	13
<b>2</b>	<b>INSTALLATION SPECIFICATIONS.....</b>	<b>14</b>
2.1	General.....	14
2.2	Commission table.....	15
2.3	Installation specifications M-SQ-Pro 15.....	16
2.4	Specifications of the accessories.....	17
2.5	Installation materials M-SQ-Pro 15 / 18.....	17
<b>3</b>	<b>DIAGRAMS &amp; DRAWINGS.....</b>	<b>21</b>
3.1	WIRING CODES AND COLORS M-SQ PRO 15 SPLIT PHASE- MARINE.....	21
3.2	WIRING CODES AND COLORS M-SQ PRO 18 SPLIT PHASE- MARINE.....	22
3.2.1	Lay out control wiring M-SQ PRO 15 SPLIT PHASE Kubota.....	23
3.2.2	Lay out control wiring M-SQ PRO 15 SPLIT PHASE Kubota.....	24
3.2.3	Lay out control wiring M-SQ PRO 15 SPLIT PHASE Kubota.....	25
3.2.4	Lay out control wiring M-SQ PRO 18 SPLIT PHASE Kubota.....	26
3.2.5	Lay out control wiring M-SQ PRO 18 SPLIT PHASE Kubota.....	27
3.2.6	Lay out control wiring M-SQ PRO 18 SPLIT PHASE Kubota.....	28
3.3	WhisperPower remote panel.....	29
3.4	M-SQ 15 dimensions and footprint.....	30
3.5	M-SQ 18 dimensions and footprint.....	31

## 1 INTRODUCTION

### 1.1 General

This manual applies to the M-SQ Pro 15/18 Marine Diesel Generating set controlled by Digital Diesel Control first launched in September 2005. For other models refer to other manuals available on our website: [www.whisperpower.com](http://www.whisperpower.com).

To ensure reliability and durability of the equipment, it is very important that the installation is carried out with the utmost care and attention. To avoid problems, such as temperature problems, noise levels, vibration, etc. the instructions set out in this manual must be followed and all installation work must be carried out professionally.

### 1.2 Location

Since WhisperPower generating sets have extremely compact dimensions, they can be installed in tight locations. Please consider that even almost maintenance-free machinery must still remain accessible.

When selecting the location area in which to mount the generating set, make sure there is sufficient room to carry out any maintenance work. The unit must be easily accessible on the service side and on the distribution side to have access to the V-belt

Please also note that in spite of the automatic oil pressure sensor it is still essential that the oil level is checked regularly.

### 1.3 Instructions for optimal sound and vibration insulation

#### 1.3.1 Further recommendations

Position the generating set as low as possible in the vessel. The generating set is already secured to the base frame by means of flexible engine mountings. The base frame can be mounted to the ship main structure. Use the included mounting template to determine the mounting spots.

WhisperPower generating sets are standard equipped with a sound cover. The canopy has been designed to give effective sound insulation. For optimum sound and vibration dampening, the following factors should be considered.

1. Most important is the structure on which the generator is places to be stiff. See figure 1. Directly below the rubber mountings the structure should be supported vertically to the superstructure of the ship.
2. Avoid mounting the generating set in close proximity to thin walls or floors that may cause resonance.
3. Sound dampening is extremely poor if the generating set is mounted on a light weight flimsy surface such as plywood which will only amplify vibrations. If mounting on a thinner surface cannot be avoided, this should be at least be reinforced with stiffening struts or ribbing. If possible, holes should be drilled or cut through the surface to help reduce the resonance. Covering the surrounding walls and floors with a heavy coating plus foam will certainly improve the situation.
4. Never connect the base of the generating set directly to bulkheads or tanks.

### 1.4 Ventilation

The generating set normally draws air from the engine room. Engine rooms with natural ventilation must have vent openings of adequate size and location to enable the generating set to operate without overheating. To allow an ample supply of air within the temperature limits of the generating set an opening of at least a half square meter (0,5 m<sup>2</sup>) is required.

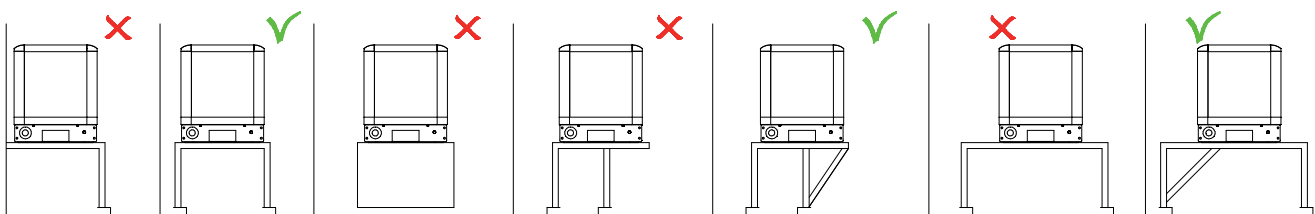

Figure 1: Mounting of the Whisper generating set. X = wrong, V = OK

A “sealed” engine compartment must have a good extraction ventilator to maintain reasonable engine room temperatures. High temperature of intake air reduces engine performance and increases engine coolant temperatures. “The rated power of the generator is measured at an ambient temperature of 25°C, each temperature increase of 5°C reduces the engine power by about 2%”. To minimize these effects the engine room temperature must not be more than 15°C above the outside ambient air temperature.

Apply a combination of ventilators, blowers and air intake ducting to meet the temperature limit. The air inlet ducts should run to the bottom of the engine room to clear fumes from the bilge and to circulate fresh air. Air outlets should be at the top of the engine room to remove the hottest air. An engine room blower should be used as an extraction ventilator to remove air from the engine room.

In cases where it is impossible to meet the above mentioned temperature limit by using machine room ventilation, connections are to be made for an air inlet directly to the enclosure. With these connections the generating set can be directly connected to an air duct.

Air inlets should be louvered, where appropriate, to protect the engine room and to protect the generating set from water spray. As an extra precaution, the fitting of a cowl ventilator with a cover box located as high as possible, is recommended.

### 1.5 Connections

The generating set comes supplied with all supply lines and output cable (i.e. electric cables, cooling water connections, exhaust, fuel lines etc.) already connected to the engine and generator. The supply lines are fed through the capsule’s base. The connections are marked as shown in fig. 2.

All electrical connections, cable types and sizes must comply with the appropriate national regulations. Supplied cables are rated for ambient temperatures up to 70°C. If the cables are required to meet higher temperature requirements, they must be run through conduits.



**ATTENTION!**

Before working (installation) on the system read the section safety instructions

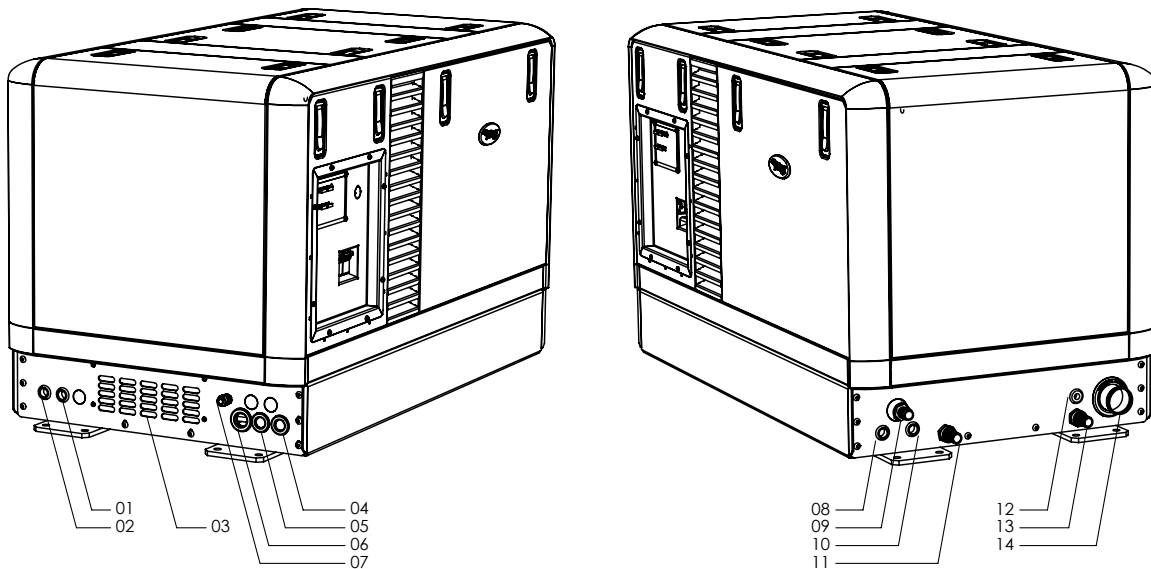

- |                                      |                          |                           |
|--------------------------------------|--------------------------|---------------------------|
| 01 Battery "black" 35mm <sup>2</sup> | 06 Communication cable   | 08 Fuel return 8mm        |
| 02 Battery "red"35mm <sup>2</sup>    | 07 Fuel pump power cable | 09 To Syphon hose 3/4"    |
| 03 Air inlet                         |                          | 10 Fuel in 8mm            |
| 04 Earth lug M10                     |                          | 11 Water in hose 3/4"     |
| 05 AC cable 3G 10mm <sup>2</sup>     |                          | 12 Drain                  |
| AC cable 4G 6mm <sup>2</sup>         |                          | 13 From Syphon hose 3/4"  |
| AC cable 5G 4mm <sup>2</sup>         |                          | 14 Exhaust hose conn. ø50 |

Figure 2: Whisper generating set connections

### 1.5.1 Fuel supply

#### 1 FUEL TANK

Fuel tanks should be made of appropriate material such as (stainless) steel or plastic. Steel tanks should not be galvanized or painted inside. Condensation can occur in metal tanks when temperature changes. Therefore, water accumulates at the bottom of the tank and provisions should be made for the drainage of this water.

The tank will need a filling connection, a return connection and an air ventilation connection which will require protection against water entry.

Some official regulations do not allow connection points at the base of the fuel tank; in this instance connections are to be made at the top of the tank with internal tubing down to a few cm above the bottom of the tank.

#### 2 FUEL LIFT PUMP

The generating set itself is equipped with a fuel lift pump; therefore the tank can be installed at a lower level than the generating set. The maximum suction height is 1 m. The M-SQ- PRO 18 has a mechanical fuel lift-pump that should be primed manually before the first start/use.'

If the pump has to lift the fuel higher than one meter an external electrical fuel lift pump must be installed (Art. No. 50201161) or heavy duty pump (Art. No. 50201168). The control board is already prepared to connect an extra fuel pump.

#### 3 FUEL PIPES

When the tank is above the generating set we recommend ending the return line on the top of the tank.

When the return is on the top- in case of a leakage the return line cannot overflow because of siphoning. One will only need a fuel cock in the fuel supply line (see figure 3). When the tank is below the generating set we recommend ending the return line on the bottom of the tank (A) below the inlet of the supply line (see figure 4)

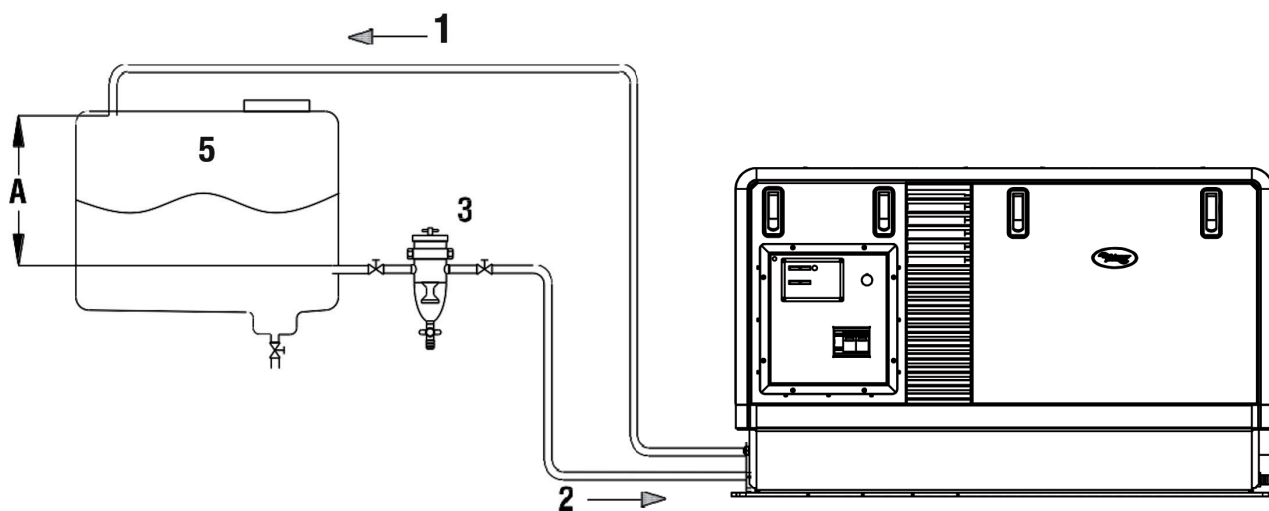

Figure 3: Fuel supply

1. Fuel return
2. Fuel supply
3. Prefilter / Water separator (optional)
5. Fuel Tank

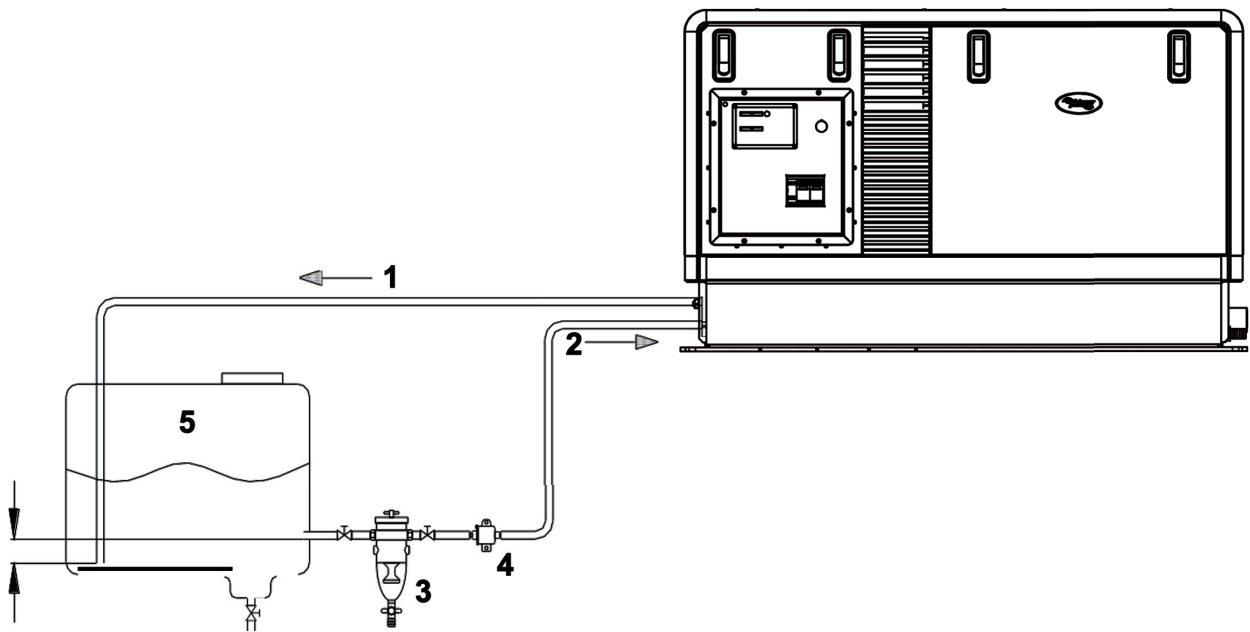

Figure 4: Fuel supply

1. Fuel return
2. Fuel supply
3. Prefilter / Water separator (optional)
4. Extra fuel lift pump (optional)
5. Fuel tank

Both supply and return fuel pipe lines should be appropriate material and 8 mm outer diameter tubing. The quality of the tubing of fuel pipes could be submitted to local regulations depending on the application of the vessel.

The fuel pipes can be plumbed to the flexible hoses which are on the generating set and have a connection to fit to 8 mm pipe. This fuel lines fulfills CE standards and are in accordance with ISO 7840 A2. It is important to avoid bends in the pipes, as they could trap air bubbles. The return pipe should never be connected to the suction pipe or to other consumers of diesel fuel, such as the propulsion engine and heaters and return pipes

**4 FUEL FILTERS**

A fine fuel filter is installed which requires maintenance. WhisperPower advises to install an extra fuel filter/ water fuel separator near the fuel tank.

Before starting your generating set for the first time follow the fuel system bleeding procedure in the user’s manual.

**1.5.2 Cooling**

Intercooling is based on a raw water pump, heat exchanger and water-injected exhaust. Cooling liquid in the internal cooling system is cooled in a heat exchanger by outboard water (raw water or seawater). After the raw water is warmed up in the heat exchanger it is dumped overboard by injecting it in the exhaust.

The generating set should have its own sea water (coolant water) inlet and should not be connected to any other engine systems. A properly installed cooling system is critical to keep engine temperatures within an acceptable range. Ensure that the installation complies with the following installation instructions.

**1 THE INTERNAL COOLING SYSTEM**

The internal cooling system should be filled with cooling liquid. (Refer to the user’s manual 2.5.13) When the engine becomes hot the liquid expands and the system is pressurized. After the pressure becomes too high the release valve in the filling cap on the manifold opens and the expanding liquid is pressed into the expansion tank that is in the delivery. Also the air in the system that is collected at the top of the manifold is released in this way. When the liquid cools down there will be under-pressure. Another valve opens and the liquid is sucked into the manifold again. This system works only when there is enough liquid initially. This has to be checked when commissioning the generator set. By filling up the expansion tank when necessary there will always be enough liquid in the system. The hose that is in the delivery has to be connected to the connection on the side of the filling cap. This hose is made of heat resistant plastic and is not sensitive for kinks.

The hose goes through a hole in the canopy

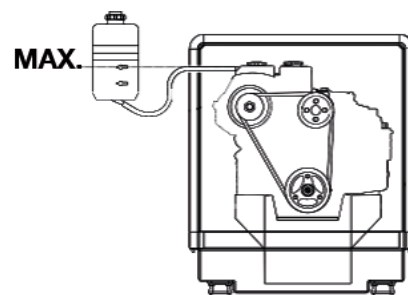

Figure 5: Expansion tank placement

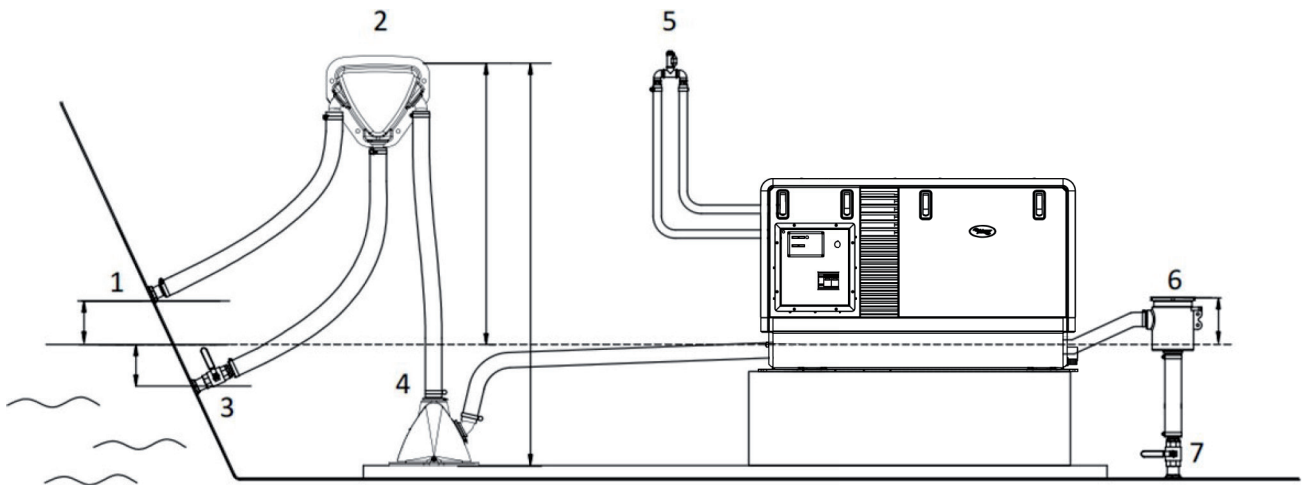

Figure 6: Internal cooling system

- 1 Water level;
- 2 Water/exhaust separator;
- 3 Seacock;
- 4 Waterlock;
- 5 Air vent;
- 6 Water strainer;
- 7 Seacock.

**2 RAW WATER SUPPLY**

For raw water supply the following installation materials are required: -a skin fitting- a sea cock- a water strainer- hoses and clamps. In order to keep the suction resistance in the line at a minimum, the sea water intake system (i.e. sea cock, trough-hull fitting, inlet filter, etc.) must have an inner diameter of at least 25.4 mm diameter (1"). The suction hose should be kept as short as possible. Raw water plumbing should avoid bends as much as possible. Restriction of raw water flow, caused by kinked hoses, undersized pipes or connections, will reduce the engine cooling capability. This is the main cause for overheating of an engine.

After running the generating set for the first time, check the coolant flow rate using a stopwatch and by holding a pail of a known volume under the wet-exhaust outlet. The flow rate should be according to the data in the user's manual

**3 INSTALLATION OF THROUGH HULL FITTING**

It is good practice for yachts to use a hull inlet fitting with an integrated strainer (water scoop). For propulsion engines in motorboats the water scoop is often mounted against the sailing direction to induce more water intake for cooling.



This should not be done in the case of a generating set! When sailing at higher speeds, water will be forced into the inlet and your generating set will overflow! (see figure 7).

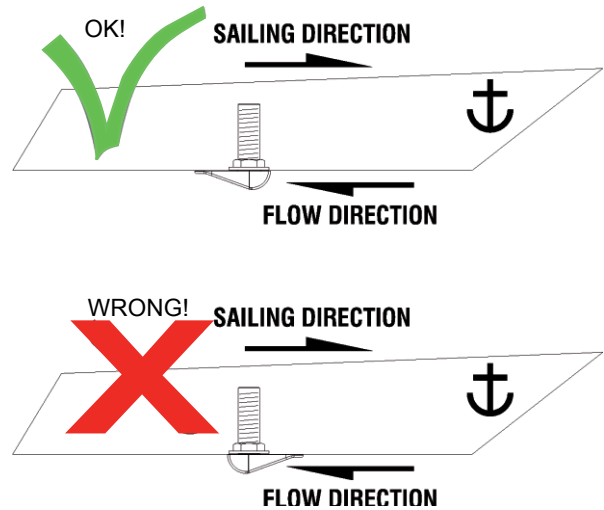

Figure 7: Installing water intake

On motorboats and on sailing boats the water scoop for a generating set should be fitted with the opening faced backwards to prevent water being forced in during sailing.

**4 WATER STRAINER**

Use an appropriate water strainer with connections of 25.4 mm (1"). Install the water strainer in a well accessible position, 5 cm above the waterline (see fig. 6, ref. 6).

**5 SIPHON BREAKER (AIR VENT)**

When the point of water injection is below the waterline, then -when the engine is stopped- there is a risk that the cooling water may enter the engine as a result of siphoning. To avoid this happening, the generating set is designed to accommodate a siphon breaker (air vent). See page 18 Syphon Breaker kit. In the standard delivery the connections are bypassed. Hose of 25.4 mm (1") inner diameter should be used.



If the generating set cannot be mounted such that the bottom of the generating set is placed above the waterline, an air vent must be installed.

Extend the water hose of the by-pass 60 cm above waterline and install an air vent. Ideally, the air vent should be mounted above the yacht keel centre line (i.e. to minimize the influence of swaying on the water intake). See figure 6, ref. 5.

Fast motorboats will lay deeper when sailing at large speed and can cause pressure on the water inlet. This should be avoided to prevent flooding the engine.



If the air vent is clogged the water hoses will not be vented when the generating set has stopped and water can be forced into the engine. This leads to immediate engine problems and eventually severe damage!

**DAMAGE CAUSED BY THE INGRESS OF WATER IN THE ENGINE IS NOT COVERED BY GUARANTEE**

**1.5.3 Exhaust system**

Water is injected in the exhaust system of the generating set. In this way the cooling water that has passed the heat exchanger is mixed with the exhaust gases. Temperature and volume of the gases are thereby reduced considerably, so that a rubber exhaust hose can be used and the level of noise is reduced as well.

**1 STANDARD EXHAUST SYSTEM INSTALLATION**

The generating set exhaust system must remain completely independent and separate from the exhaust system of any other engine on board. A water lock prevents the generating set from being flooded by cooling water and should be installed as close to the generating set as possible. The lock must be large enough to hold the entire water volume held in the hose from the top of the goose neck to the water lock. The water lock must be installed at the lowest point of the exhaust system (ref. to fig. 8, ref. 1). The exhaust hose must have an inner diameter of 50 mm (1½”). The exhaust system must be installed so that the back pressure inside the exhaust does not exceed 0.07 bar (1psi – 70 cm water column) and total length from the generator to the top of the goose neck or water/separator does not exceed 3m (10 ft.). (Refer to paragraph 5.4.3 of the user’s manual).

The exhaust hose descends from the capsule to the water lock. Then the hose rises via the “goose neck” to the through-hull exhaust outlet, situated minimum 50 mm above the water line (see fig. 8, ref 5.) The “goose neck” must be vertical and situated preferable along the ship’s keel centre line. If the generating set is mounted less than 600 mm (24”) above the waterline, a “goose neck” must be installed to prevent the engine from overflowing. It is recommended to install an extra muffler close to the through-hull fitting.

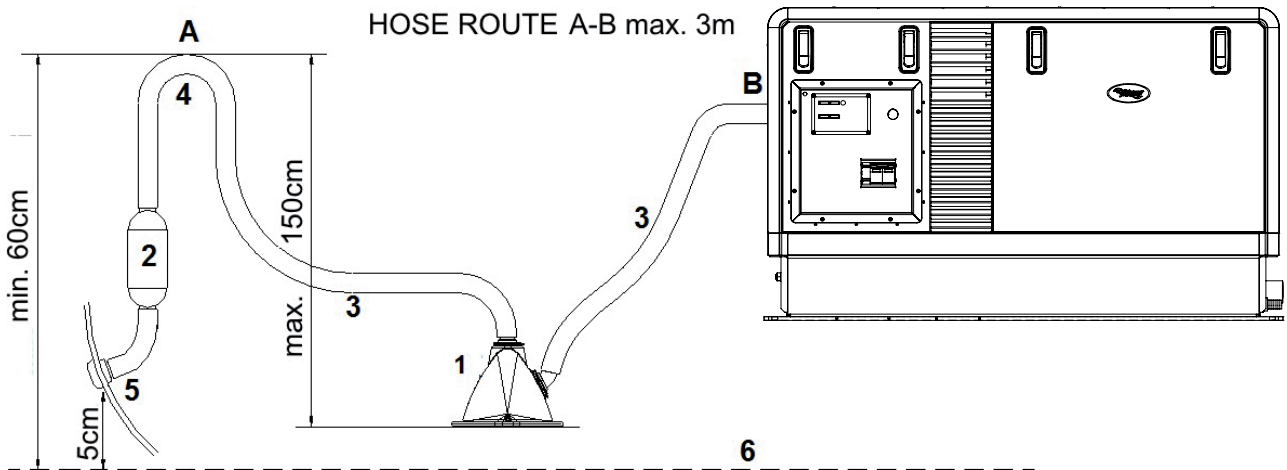

Figure 8: Exhaust system

- 1 Exhaust water lock;
- 2 Exhaust outlet muffler;
- 3 Exhaust line Ø 50 mm (1½”);
- 4 Goose neck
- 5 Through-hull exhaust outlet Ø 63 mm (2½”);
- 6 Water level.

2 "SUPER SILENT" EXHAUST SYSTEM

In order to reduce the noise level of the generating set to a minimum, an option to reduce the exhaust noise further (especially exhaust water splashing) is an exhaust/water separator. The exhaust/water separator allows the cooling water to be ejected through a line (figure 9, ref. A) separate from the exhaust fumes and also functions as a goose neck to prevent water from flooding the engine. If the exhaust/water separator is mounted more than 60 cm above the water level an additional goose neck is not required.

If the through-hull exhaust outlet has to be mounted far from the generating set an exhaust/water separator must definitely be installed (Total length of the exhaust piping from generator to top of goose neck (water separator) is more than 3 m.) (ref. to fig. 10).

The sea water from the separator must then run down along the shortest possible path to the through-hull outlet. Only after the exhaust/water separator the exhaust hose may have a length of over 7,5 m (ref. to fig. 10)

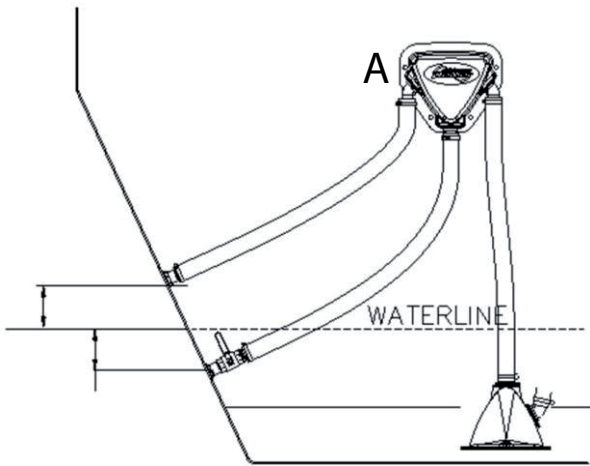

Figure 9: Super silent exhaust system

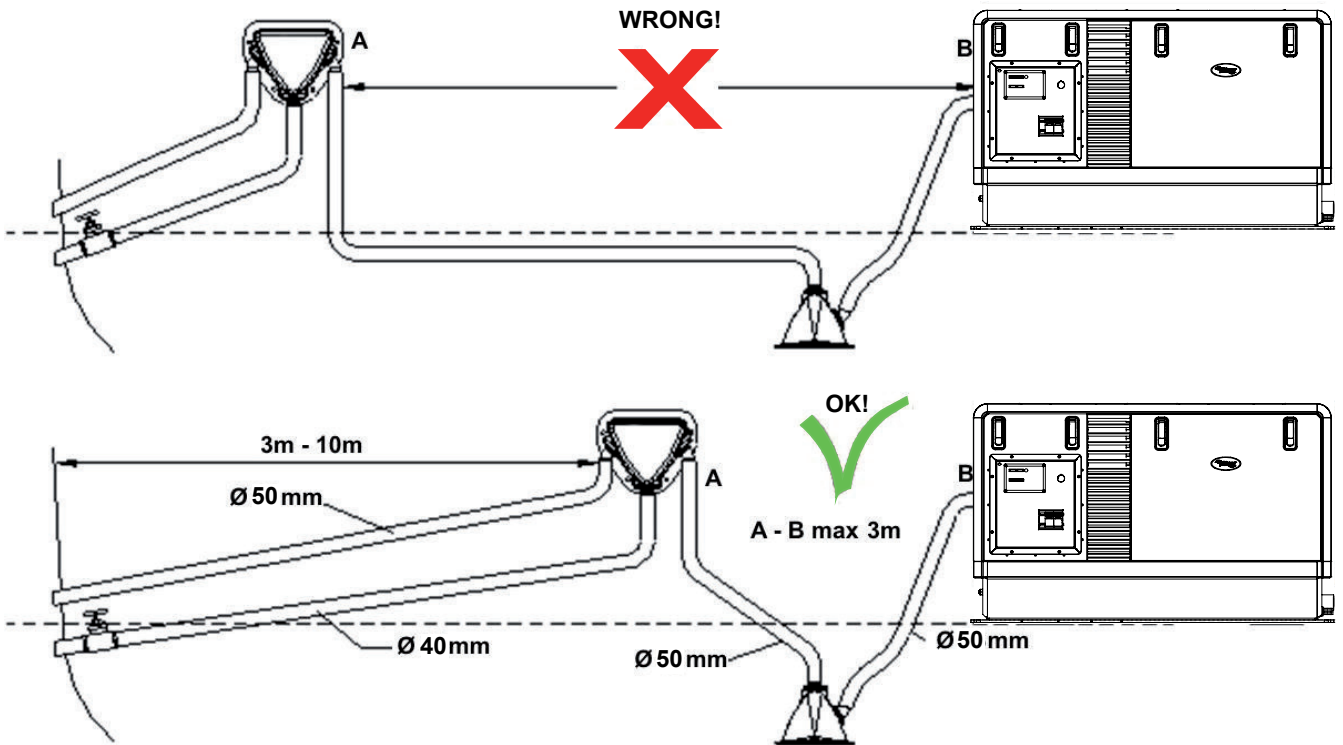

Figure 10:

However water traps should be avoided as the fumes still contains water and this should not accumulate in bends (see fig. 11). An additional outlet exhaust muffler close to the hull outlet will help further to reduce noise emission (figure 8, ref. 2)

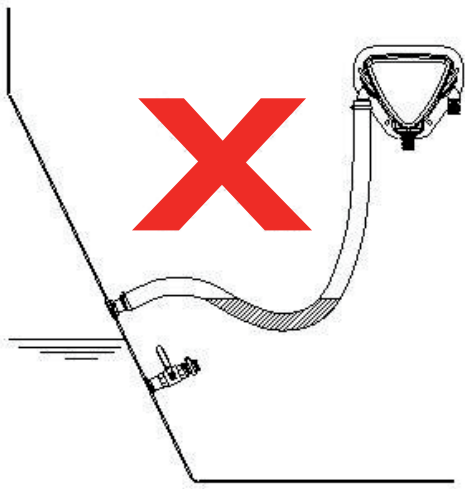

Figure 11: Water trap in exhaust system

If the generating set and the exhaust system have been installed correctly, neighbouring boats will not be disturbed by generating set noise. With the “super silent” exhaust system, generating set noises are almost inaudible. For optimal noise reduction, the sea water outlet from the exhaust/water separator (centre outlet on the unit, see figure 9) should be installed below the water level to eliminate noisy splashing of the effluent sea water.

The through-hull outlet for the exhaust fumes should not direct the fumes directly toward the water surface as this will cause excessive noise (see fig. 12).



Do not direct the outlet directly toward the water surface.

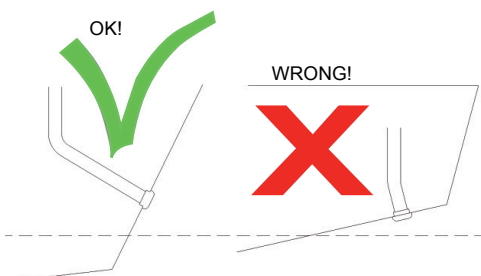

Figure 12: Outlet direction

### 1.5.4 Digital Diesel Control system (12 Volt)

#### 1 DIGITAL DIESEL CONTROL SYSTEM

The electrical control system is standard in 12 Volt with negative earth. Non- earth return is available as an option for aluminium vessels to prevent corrosion.

All electrical wiring has been prepared on the generating set to the control panel prior to despatch from the factory. The engine is controlled by a very advanced microprocessor based system: Digital Diesel Control.

The “black box” containing the microprocessor is located on top of the alternator. A local control panel is on the generating set.

#### Remote control

A remote control panel also containing a microprocessor is in the delivery. A 15 m intermediate 8-pole communication cable is in the standard supply too (refer to fig. 13). If necessary an optional longer (up to 30m / 100ft) intermediate cable can be connected if the standard length does not suit the required distance. When a longer distance than 30m / 100ft is required, consult the WhisperPower service department for advice.

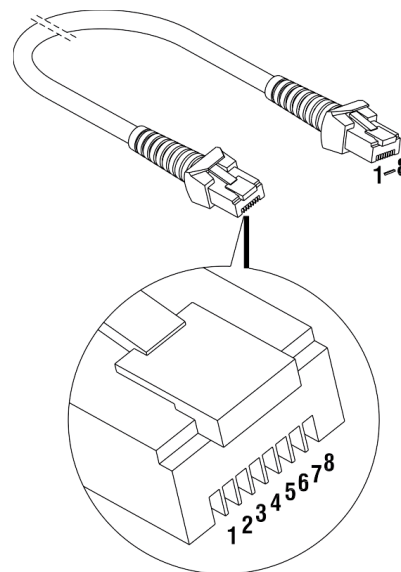

Figure 13: Remote control cable

One can mount the control panel after drilling a hole in the dash-board using the plastic cover. Refer to the dimensional drawing in paragraph 3.5.

More remote control panels (slave panels) can be put in parallel by using the modular connectors on the back of the units. As a slave one can use the same panel offering all functions again. It is also possible to use an old or new type slave panel only to start and stop the generator.

Old type remote panels and system panels can be connected by means of the green connector.

Pay attention to the color codes as indicated in fig. 14 when fit-

ting cable to the green connector. Some software versions in old system panels (supplied before May 2004) could conflict with the software in the DDC and an update of the software of the system panel could be necessary. When this is the case consult to the WhisperPower service department for advice.

When using the factory settings, installation is very simple: just plug the remote cable into the remote and the generator is ready to use. Refer to fig. 14.

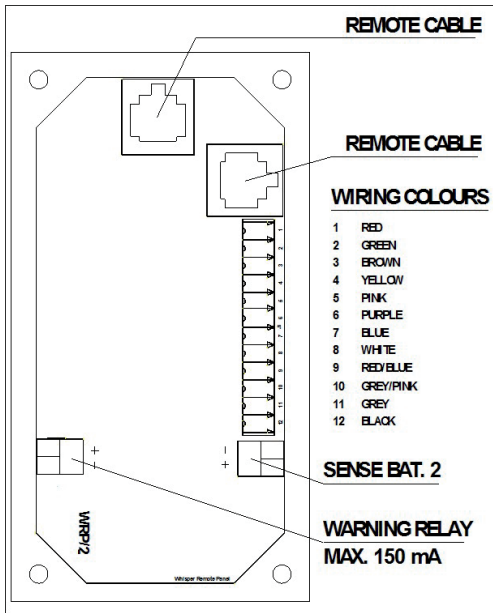

Figure 14: Remote box terminals

**Acoustic alarm or warning lamp**

One can connect an external max.150 mA relay to generate an acoustic warning or applying a warning lamp etc. Be aware of polarity as some relays has a diode inside and should be connected plus to plus and minus to minus as indicated. Refer to fig. 14.

**Connection for emergency stop / fire alarm switch**

To connect an emergency stop button or to stop the generator automatically in case of a fire alarm, you can use the bypass connection between fastons J7 and J18 on the backside of the local control panel. See fig. 15. To do so, remove this bypass connection and then replace it by an emergency switch or a potential free fire alarm switch with normally closed contacts

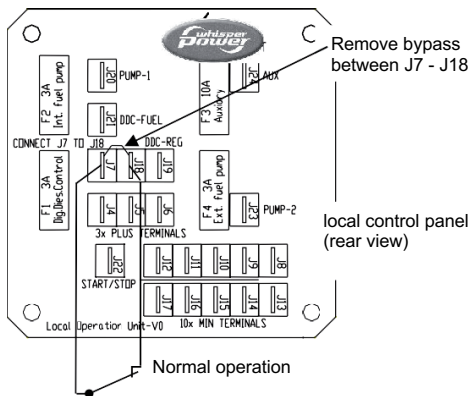

Figure 15: Connection for emergency stop / fire alarm switch

**Automatic start/stop**



**WhisperPower cannot be held responsible for damage caused by the unattended running generator using the auto- start/stop mode or interval mode.**

**Using the auto-start/stop (interval) mode the generator can start unexpectedly. When working on the electrical system, the 3 Amp fuse must be removed from the control panel and the battery plus cable must be removed from the battery.**

The WhisperPower Digital Diesel Control system offers several options for automatic starting and stopping.

Access to this menu and other menus could be blocked. For blocking and setting up this options refer to the APPENDIX of the DDC user’s manual.

One of these options is to monitor a second battery (not being the starter battery) to start the generator automatically when the voltage of this battery drops below a certain setting.

Other names for this second battery are “auxiliary battery”, “service battery”, “users battery” or “consumers battery”. We will refer to this battery as “the second battery” (BAT2). In some menus the starter battery could be indicated as “the first battery” (BAT1).

A sense wire to monitor the second battery should be connected (attention polarity!) to the connector on the back of the remote panel. Refer to fig. 14. The sense wires must be connected directly on the second battery before a main switch and be protected by a 3 Amps fuse. (Monitoring the generator starter battery does not require an extra sense connection)

**Settings**

When one want to apply other settings than the factory settings refer to the DDC user’s manual, especially to the APPENDIX.

For starting, the WhisperPower requires a battery with a capacity of M-SQ15: 55 Ah, M-SQ18: 80 Ah. The generating set can be connected with the main engine battery or have its own battery.

We strongly recommend the use of a separate battery for the generating set and to keep the wiring system for the propulsion engine and the domestic DC supply system completely separate and individually connected to separate batteries.

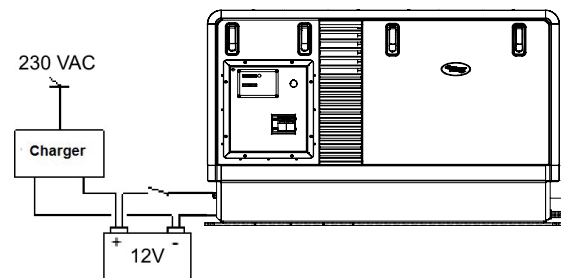

Figure 16: Starter battery

However, the negative of all the batteries on the vessel should be interconnected (when on earth) to avoid difference in the voltage level of the earth on different places causing trouble to electronic devices which might be in the system.

The above recommendation is not valid for ships having the starter battery of the propulsion engine or other auxiliary equipment positive grounded. When this is the case an expert should be consulted.

A battery switch may be used to interrupt the positive connection.

The starter battery is charged by the alternator on the engine. An additional battery charger will help to keep the battery in good condition when the generating set is not used. A battery charger is not included in the standard supply. A high efficiency battery charging unit can be ordered from WhisperPower which is able to charge both the ship's main battery and the starter battery. Also a small charger can be used to charge the starter battery only, such as the WBC Handy 70. A battery switch and a charger are included in the battery installation kit (refer to 2.5).

### 3 OTHER RECOMMENDATIONS AND WARNINGS

The battery should be secured for seagoing conditions and the terminals should be insulated. For extra safety the battery can be enclosed in a wooden, plastic, fibreglass etc. (non-metal) box. Even when the earth return system is applied a negative battery cable should be used and the vessel should not to be used as a conductor.

The battery cables are supplied in a standard length of 1.5 m, if longer cables are required a larger cross sectional area should be considered to compensate for voltage reduction.

When two batteries are used in series to provide a 24 Volt supply system, never take off 12 Volt (starting) power from one of these batteries. This will result in severe damage to the batteries within a short time.

Disconnect the battery leads if electrical welding is to be carried out, otherwise damage will be caused to the diodes of the alternator.



As explosive hydrogen gases are discharged during charging, the battery should be located in a well ventilated room. Ensure that the supplied battery cable connectors are properly fitted and never remove during or shortly after charging as sparking can occur, which may ignite the hydrogen gases.

#### 1.5.5 AC power system (230 / 400 Volt)



Before working (installation) on the system read the sections on safety in the user's manual.

Be sure that all electrical installations (including all safety systems) comply with all required regulations of the local authorities. All electrical safety/shutdown and circuit breaking systems have to be installed on board as the generating set itself cannot be equipped with such equipment for every possible variation.

The vessel's power supply system should be suitable and safe for the AC voltage which is applied and the power that will be generated. Special attention has to be paid on dividing the system in branches which are fused individually.

It is absolutely essential that each and every circuit in the on-board electrical system is properly installed by a qualified electrician.

The M-SQ15 and M-SQ18 can be connected as a single phase 230 Volt generator by an arrangement of the wiring in double DELTA. When the wires are arranged in STAR the output will be 230/400Volt.

Connected as a three phase 230/400 Volt generator, 3x400 Volt is available between the phases. At the same time 230 Volt is available between every phase and neutral.

When applying 3 phases the installation should be laid out in such a way that there is a reasonable balance of load between the three phases.

To avoid problems with unbalanced loads one could apply a 400V 3 phase to 230 Volt single phase transformer.

#### 1 FUSE

An input fuse (from the generating set to the system) should be installed to protect the installed electrical system.

For the Whispers the maximum single phase current at 230V is 87 Amps. Using three phases the fuses should be capable of withstanding three times 29 Amps and mechanically connected. The fuses must be of the slow reacting type. For electrical motors connected to the system, a motor protection switch must be installed.

#### 2 GROUNDING

The AC alternator windings are not grounded. The housing of the alternator and all other metal parts are grounded.

To make a connection between "neutral" and "ground" is necessary as part of a specific insulation failure protection system.

Small pleasure craft in Europe (length up to 24 meter) is submitted to The Recreational Craft Directive 94/25/EC. The guidelines of this directive refer to (ISO 13297).

When the installation comply to this standard the "neutral" and "ground" should be connected on the generating set by connecting the blue (neutral) wire with the terminal on which the yellow/green wire is connected.

A Ground Fault Circuit Interrupter (GFCI) or similar device must be applied

**WARNING**

In all situations the transfer switches between shore, inverter and generator should switch all connections, the line(s) as well as neutral.

Be aware that insulation protection systems can be different for different applications and even within the ship there could be different standards for different spaces. We did refer to the Recreational Craft Directive that applies to pleasure craft up to 24 m of length. Sometimes one has to comply with other standards such as the rules of certification societies like Lloyd's Register of Shipping or Veritas, regulations for the protection of personal, building legislation, etc. It is of the greatest importance to have expert advice on this issue.

For safety reasons connect the main ships ground to negative point of the generating set start battery. When a ungrounded DC system or positive grounded DC system is applied the battery negative should not be connected to the main ships ground.

**3 CABLE**

For the power cable we recommend the use of 3 wire single phase or 5 wire tri-phase oil resistant cable with a sufficient cross sectional area. One wire for earth is included. For long cables it is recommended to apply cables with a larger cross section (refer to ISO 13297 annex A)

**4 TRANSFER SWITCH**

A power source selector switch must be installed between the generating set and the ship's electrical supply system. This switch must ensure that all AC consumers can be switched off at once. This switch should also be installed to keep the generating set and shore (grid) power systems separate.

Transfer switches- to switch over from shore to ship or from generating set to inverter- should be well designed to switch over all wires including neutral (and not only phases or line) and there should be provisions with the aid of timers to prevent relays from clattering.

**2 INSTALLATION SPECIFICATIONS****2.1 General**

- 1 Install the generator with the 8 holes  $\varnothing 13$  on a rigid surface.

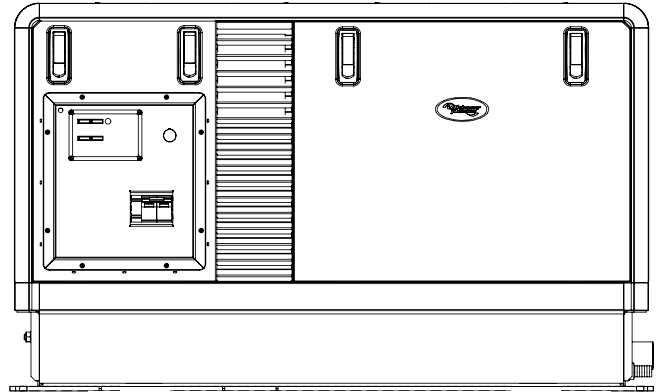

*Figure 17: Anti-vibration mounts*

- 2 Connect the (sea) water inlet to the strainer.
- 3 Connect exhaust system.
- 4 Connect a siphon breaker or 'air vent' into the cooling circuit, if necessary.
- 5 Connect 'fuel supply line' to the water separator/ fuel filter.
- 6 Connect 'fuel return line' to the fuel tank.
- 7 Connect remote panel (just plug in).
- 8 Connect the AC cable from the AC box to the power source selector or WhisperSwitch.
- 9 Connect plus and minus from the 12V starter battery to the battery cables.
- 10 Install a WhisperPower battery charger. (optional)

## 2.2 Commission table

- 1 Check if a siphon breaker (air vent) is necessary and has been installed.
- 2 Open the seawater inlet valve and check all water connections. Check if the strainer is installed on or just above the seawater level.
- 3 Check if the exhaust system is properly installed. Check maximum length of exhaust hose, diameter of exhaust hose, position of the water lock, maximum lift. Also check the minimum required height of 60 cm above sea level of the exhaust loop (goose neck).
- 4 Open the seawater outlet valve and check all water connections.
- 5 Check the AC cables and the grounding.
- 6 Check if an AC breaker is installed before or after the power source selector. When there is only a circuit breaker, use it to disconnect the generating set from the grid.
- 7 Check all DC connections, check if the battery switch/ circuit breaker is closed.
- 8 Open the fuel valve. Check if there are no air leaks in the fuel supply line, and check if the lift of the fuel is less than 1 meter. Check if there is no air in the water fuel separator.
- 9 To bleed the fuel system use the manual pump by turning the cap loose and pumping as long as necessary to bleed the system
- 10 Check if the air intake in the canopy is not blocked.
- 11 Check the oil level and colour of the oil. Check the coolant level
- 12 Start the engine by pushing the start button
- 13 Check when the generating set is running, the delay of 5 to 10 seconds in the power source selector transfer.
- 14 Check voltage and frequency under 'no load' conditions.
- 15 Check voltage and frequency under 'full load' conditions.
- 16 Check if the battery charger of the generating set is working (max. 14.5 Volt).
- 17 Close the sound shield and check the noise level.
- 18 Stop the generating set and check the engine again for leakages of oil, fuel or water.



## 2.3 Installation specifications M-SQ-Pro 15

	M-SQ Pro 15	M-SQ Pro 18
<b>GENERAL</b>		
RPM	1500-1800 rpm	1500-1800 rpm
Alternator	Split Phase	
Engine	Kubota diesel, model V1505 BG	V2203 BG
Number of cylinders	4	4
Displacement	1498 cm <sup>3</sup>	2197 cm <sup>3</sup>
Bore X stroke	78,0 x 78,4 mm	87 x 92,4 mm
Combustion air consumption	1,5 m <sup>3</sup> /min.	1,52 m <sup>3</sup> /min
Continuous power 60 Hz	12 kW electric power	16 kW electric power
Cooling system	indirect cooling by raw water, 20-25 l/min.	35 l/min.
Cooling water pump	PTO driven WhisperPower self-priming impeller pump	
Fuel lift pump engine	Mechanical pump, additional electrical pump available upon request	
Starting battery (optional)	55 Ah 12V	80 Ah 12V
Fuel consumption	247 g/KWh	235 g/KWh
Control	DDC or Deepsea	DDC or Deepsea
<b>ELECTRICAL SPECIFICATIONS</b>		
Output voltage	240V 50Hz, 1Phase 240/400V 50Hz 3Phase 240/120V 60Hz Split-Phase	240V 50Hz, 1Phase 254/440V 50Hz 3Phase 240/120V 60Hz Split-Phase
Continuous power kW at 25°C (77°F)	11 kW, Stage V   12 kW, Non-Stage V	14 kW, Stage V   16 kW, Non-Stage V
Voltage tolerance	± 2% (balanced load)	
Frequency tolerance	± 3%	
Alternator	Air cooled, brushless, 1Phase 3 wires, 3Phase 5 wires	
Voltage regulation:	AVR	AVR
<b>MECHANICAL SPECIFICATIONS</b>		
Supply includes	Sound shield with steel base, mounted on rubber anti vibration mounts. (Genset without sound shield is optional)	
Dimensions in sound shield L x W x H	1145 x 625 x 690 cm	1220 x 719 x 754 cm
Dimensions without sound shield	984 x 462 x 625 cm	999 x 568 x 681 cm
Colour:	white / black	white / black
Weight with sound shield	410 kg	495 kg
Weight without sound shield	370 kg	455 kg
Max. Operation angle	20 degrees	20 degrees
Standard supplies	Remote panel (+15 m cable), fuel filter, fuel lift pump, user and installation manuals	
Optional	Installation kits, non-earth return (ungrounded), spare part kits,	



2.4 Specifications of the accessories

	M-SQ Pro 15	M-SQ Pro 18
Water scoop	3/4" = 20 mm	1" = 25,4mm
Inlet valve	3/4" in / 20 mm out	1" in / 25,4 mm out
Water strainer	20 mm in, 20 mm out	25,4 mm in, 25,4 mm out
Air vent	20 mm	25,4 mm
Inlet suction hose	20 mm	25,4 mm
Fuel filter/water separator	30 micron	30 micron
Fuel inlet and return	8 mm	8 mm
Exhaust hose	∅ 50 mm inner	∅ 50 mm inner
Water lock	∅ 51 mm	∅ 51 mm
Water/gas separator	∅ 51- 40- 51 mm	∅ 51- 40- 51 mm

2.5 Installation materials M-SQ-Pro 15 / 18

WATER INLET KIT

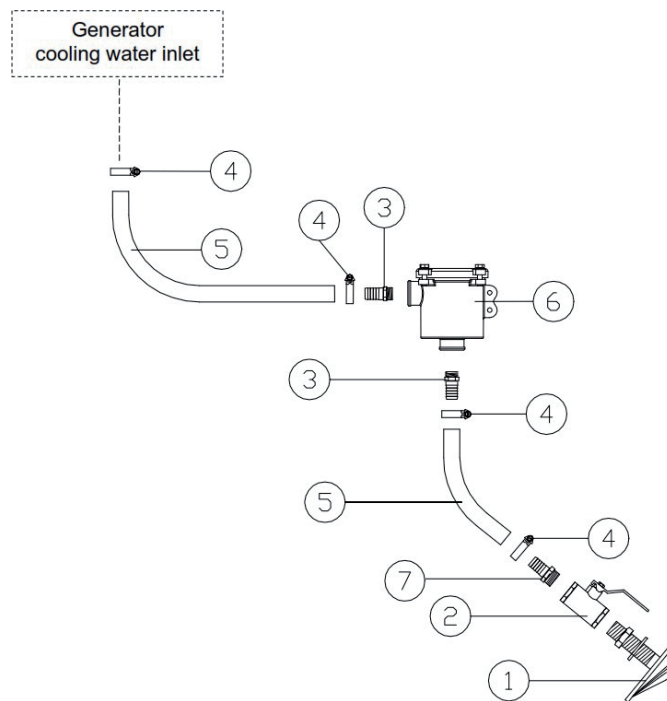

No	Qty	Article No	Description	Dimensions
1	1	50230052	Water pickup scoop	3/4"
2	1	50230042	Lever operated ball valve f/f	3/4"
3	2	50221004	Male hose connector	3/4" x 20 mm
4	4	50221502	Hose clamp, stainless	20-32 mm
5	3	50220056	Raw water hose	19 x 26 mm
6	1	50230062	Nickel plated brass intake strainer	3/4"
7	1	50230004	Male hose connector	3/4" x 20 mm
<b>TOTAL</b>		<b>40230211</b>	<b>WATER INLET KIT 20 mm (3/4") M-SQ-Pro 15</b>	

No	Qty	Article No	Description	Dimensions
1	1	50230053	Water pickup scoop	1"
2	1	50230043	Lever operated ball valve f/f	1"
3	2	50221008	Male hose connector	3/4" x 25 mm
4	4	50221503	Hose clamp, stainless	25-40 mm
5	3	50220050	Raw water hose	25 x 33 mm
6	1	50230061	Nickel plated brass intake strainer	¾"
7	1	50221010	Male hose connector	1" x 25 mm
<b>TOTAL</b>		<b>40230221</b>	<b>WATER INLET KIT 25 mm (1") M-SQ-Pro 18</b>	

**SYPHON BREAKER KIT**

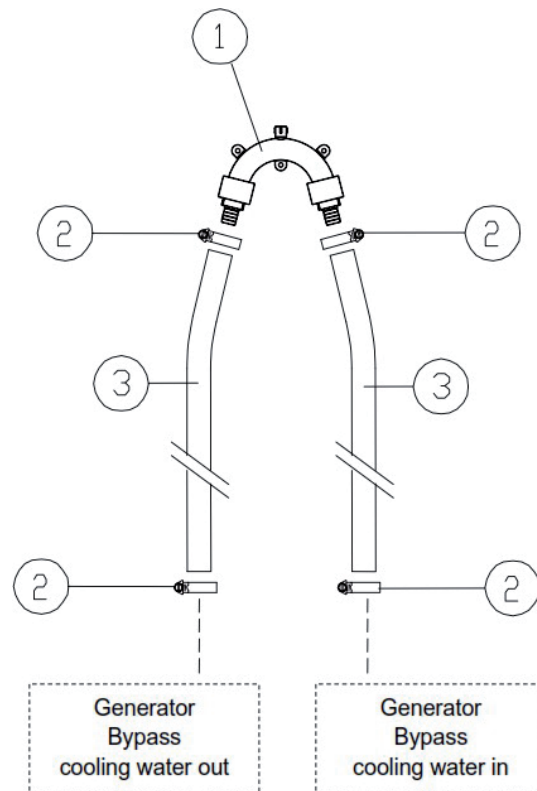

No	Qty	Article No	Description	Dimensions
1	1	50230019	Syphon breaker (including valve assembly)	19 mm
2	4	50221502	Hose clamp	20-32 mm
3	3 m	50220056	Raw water hose	19 x 26 mm
<b>TOTAL</b>		<b>40230273</b>	<b>SYPHON BREAKER KIT 19 mm (3/4") for M-SQ-Pro 15</b>	

No	Qty	Article No	Description	Dimensions
1	1	50230025	Syphon breaker (including valve assembly)	25 mm
2	4	50221503	Hose clamp	25-45 mm
3	3 m	50220050	Raw water hose	25 x 33 mm
<b>TOTAL</b>		<b>40230273</b>	<b>SYPHON BREAKER KIT 25 mm (1") for M-SQ-Pro 18</b>	

**WATER SEPARATOR AND WET EXHAUST KITS (51 mm)**

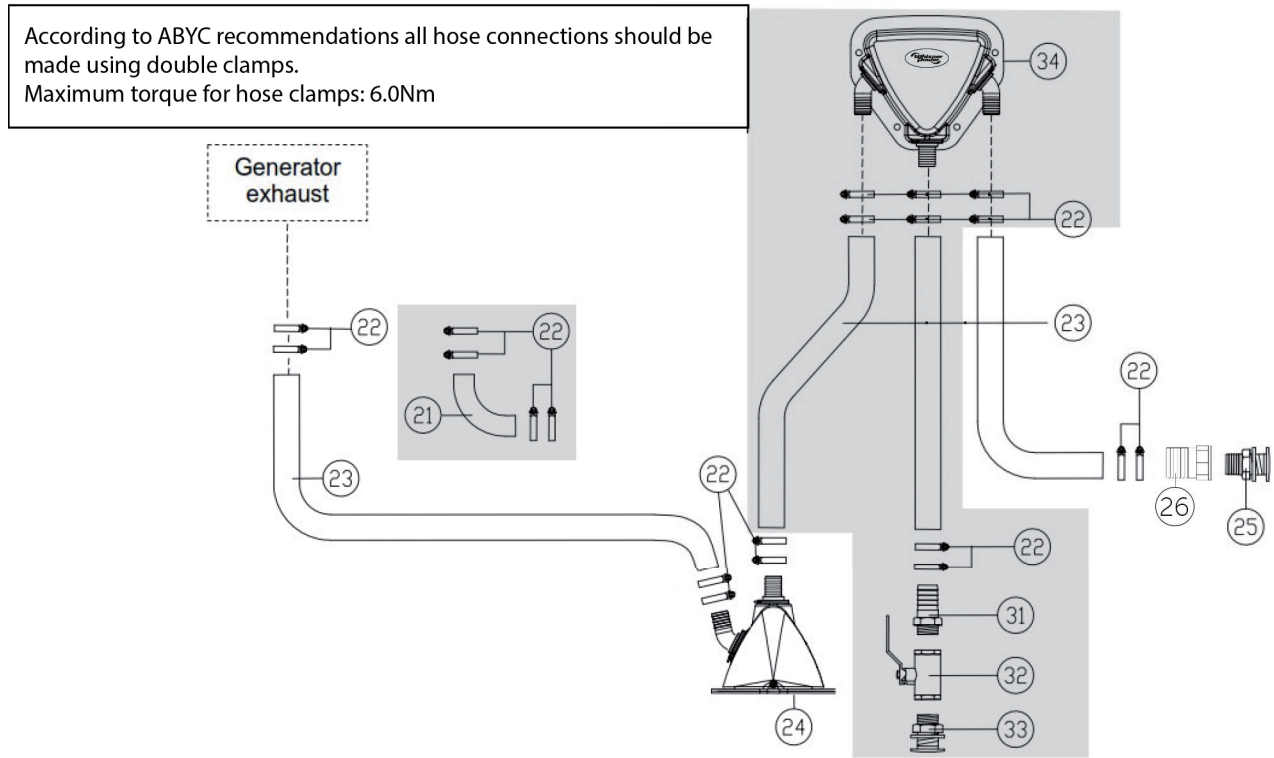

No	Qty	Article No	Description	Dimensions
22	8	50221505	HD hose clamp	40-60 mm
23	3m	50220035	Marine exhaust hose	51 mm inner
24	1	40230084	Water lock	51 x 51 mm
25	1	50230034	Brass through hull fitting	1½" x 70 mm
26	1	50221024	Female hose connector	1 ½" x 50mm
<b>TOTAL</b>		<b>40230282</b>	<b>WET EXHAUST KIT (51 mm)</b>	
22	4	50221505	HD hose clamp	40-60 mm
22	4	50221504	HD hose clamp	32-50 mm
23	1,5m	50220033	Marine exhaust hose	40 mm inner
23	2,5m	50220035	Marine exhaust hose	51 mm inner
31	1	50221015	Male hose connector	1½" x 40 mm
32	1	50230044	Lever operated ball valve f/f	11/4"
33	1	50230033	Brass through hull fitting	11/4" x 70 mm
34	1	40230088	Water separator	51 x 40 x 51 mm
<b>TOTAL</b>		<b>40230292</b>	<b>WET EXHAUST KIT (51 mm)</b>	
<b>OPTIONAL INSTALLATION PARTS</b>				
No	Qty	Article No	Description	Dimensions
21	1	50230085	Elbow 45° exhaust hose adapter	50 mm
22	4	50221505	HD hose clamp	40-60 mm

## FUEL KIT

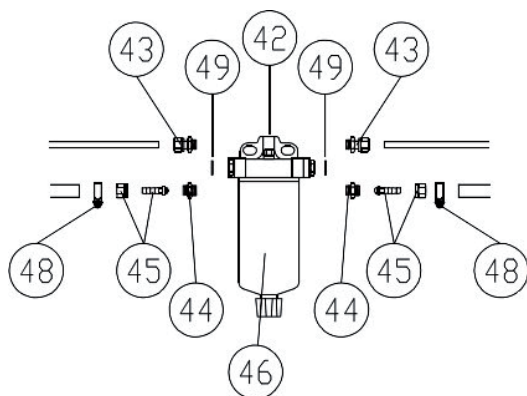

No	Qty	Article No	Description	Dimensions
42	1	50230091	Filter head for fuel strainer/water separator	M14 × 1.5 mm
43	2	50221618	Parallel male coupling	M14- 8 mm
44	2	50221619	Parallel male coupling	M14- 10 mm
45	2	50221620	Hose connection, outer cone	M16 × 1.5 mm, 8 mm
46		40230092	Filter for fuel strainer/water separator	
48	4	50221522	Hose clamp, stainless	10-16 mm
49	2	50221632	Gasket ring	18 × 14 × 1.5 mm
not shown	2	50221203	Straight coupling	8 mm
not shown	2	50221252	Barbed-smooth hose nipple	8 mm
<b>TOTAL</b>		<b>40230205</b>	<b>FUEL KIT</b>	
<b>OPTIONAL INSTALLATION MATERIALS</b>				
No	Qty	Article No	Description	Dimensions
48	1	50221522	Hose clamp, stainless	10-16 mm
not shown	per m	50222020	copper fuel pipe	6 × 8 mm
not shown	per m	50220063	fuel hose	8 × 16 mm

## BATTERY INSTALLATION KIT

Article No	Description	Dimensions
61112007	WBC-Handy 70 charger 12V / 7A	225 × 50 × 50 mm
40290093	battery terminal (NEG-)	
40290094	battery terminal (POS+)	
40290099	M8 battery pole adapter set	
40290098	isolation caps (red & black)	
502144701	WP-Compact Manual Battery Switch, 300A	72 × 72 × 78 mm
<b>40290108</b>	<b>INSTALLATION KIT FOR BATTERIES &gt; 100 Ah</b>	
<b>RECOMMENDED BATTERY</b>		
Article No	Description	Dimensions
40290031	AGM-Power 12V 100 Ah M-SQ-Pro 15	328 x 173 x 215 mm
40290062	AGM-Power 12V 145 Ah M-SQ-Pro 18	340 x 173 x 285 mm

### 3 DIAGRAMS & DRAWINGS

#### 3.1 WIRING CODES AND COLORS M-SQ PRO 15 SPLIT PHASE - MARINE

Wire number	Origin	Destination	Section	Color code
1	-M1:+	-G3:+	10 (mm <sup>2</sup> )	RD
1	-S1	-M1:+	35 (mm <sup>2</sup> )	RD
1	-M1:+	-J1:+	6 (mm <sup>2</sup> )	RD
1	-M1:+	-P1:J4	2.5 (mm <sup>2</sup> )	RD
2	-Y4:M6	-Y4:M7	1.5 (mm <sup>2</sup> )	
18	-J1:hold	-E1:~	1.5 (mm <sup>2</sup> )	GN
18	-E1:~	-Y1:Hold (RD)	1.5 (mm <sup>2</sup> )	GN
18	-G3:D+	-J1:hold	1.5 (mm <sup>2</sup> )	WH
19	-E1:~	-Y1:Pull (WT)	2.5 (mm <sup>2</sup> )	PK
19	-J1:pull	-E1:-	2.5 (mm <sup>2</sup> )	PK
20	-J1:gnd	-P1:J1	2 4 (mm <sup>2</sup> )	BK
20	-J4	-P1.1:J17	2.5 (mm <sup>2</sup> )	BK
20	-P1.1:J15,J9,J14,J8,J13	-B1 1.5 (mm <sup>2</sup> )	BK	
20	-P1.1:J15,J9,J14,J8,J13	-B2 1.5 (mm <sup>2</sup> )	BK	
20	-J4	-G2	35 (mm <sup>2</sup> )	BK
21	-J1:start	-M1:S	2.5 (mm <sup>2</sup> )	YE
23	-G3:W	-J1:alt	1.5 (mm <sup>2</sup> )	OG
24	-J1:gl	-R1	6 (mm <sup>2</sup> )	BK
37	-J1:reg	-P1:J19	1.5 (mm <sup>2</sup> )	BK
38	-J1:st	-P1:J22	1.5 (mm <sup>2</sup> )	BK
39	-J1:fuel	-P1:J21	1.5 (mm <sup>2</sup> )	BK
46	-B1	-J1:t-2	1.5 (mm <sup>2</sup> )	BUGN
47	-B2	-J1:t-1	1.5 (mm <sup>2</sup> )	BU
48	-B3	-J1:oil	1.5 (mm <sup>2</sup> )	VT
49	-P1:J7	-P1:J18	1.5 (mm <sup>2</sup> )	BK
L1-1	-Q1:1	-G1:L1	16 (mm <sup>2</sup> )	BN
L2-1	-Q1:5	-G1:L2	16 (mm <sup>2</sup> )	BK
N-1	-Q1:3	-X1-4	16 (mm <sup>2</sup> )	BU
N-1	-G1:N	-X1-4	16 (mm <sup>2</sup> )	BU

## 3.2 WIRING CODES AND COLORS M-SQ PRO 18 SPLIT PHASE - MARINE

Wire number	Origin	Destination	Section	Color code
-	-G1:BL- EXC-	-J4:F-	1.5 (mm <sup>2</sup> )	YE
+	-G1:YL- EXC +	-J4:F+	1.5 (mm <sup>2</sup> )	BU
1	-G1:GN	-J4:L1	1.5 (mm <sup>2</sup> )	GN
2	-G1:BK	-J4:L2	1.5 (mm <sup>2</sup> )	BK
10	-M1:+	-G2:+	10 (mm <sup>2</sup> )	RD
10	-S2	-M1:+	35 (mm <sup>2</sup> )	RD
10	-M1:+	-J2:+	6 (mm <sup>2</sup> )	RD
10	-M1:+	-P1:J4	2.5 (mm <sup>2</sup> )	RD
17	-M2:+	-P1:J20	1.5 (mm <sup>2</sup> )	BK
18	-G2:R	-J2:hold	1.5 (mm <sup>2</sup> )	WH
20	-J1	-P1.1:J17	1.5 (mm <sup>2</sup> )	BK
20	-P1.1:J15,J9,J14,J8,J13,J1 2	-B5	1 (mm <sup>2</sup> )	BUPK
20	-P1.1:J15,J9,J14,J8,J13,J1 2	-B1	1 (mm <sup>2</sup> )	BUBK
20	-M2:-	-P1.1:J10	1.5 (mm <sup>2</sup> )	BK
20	-P1.1:J15,J9,J14,J8,J13,J1 2	-J3:E	1.5 (mm <sup>2</sup> )	BK
20	-J2:GND	-P1:J12	1.5 (mm <sup>2</sup> )	BK
20	-J1	-G3	1.5 (mm <sup>2</sup> )	BK
21	-J2:start	-M1:S	2.5 (mm <sup>2</sup> )	YE
24	-J2:gl	-R1	1.5 (mm <sup>2</sup> )	BK
32	-J3:A	-Y1:2	1.5 (mm <sup>2</sup> )	BK
33	-J3:B	-Y1:1	1.5 (mm <sup>2</sup> )	BK
37	-J2:reg	-P1:J19	1.5 (mm <sup>2</sup> )	BK
38	-J2:st	-P1:J22	1 (mm <sup>2</sup> )	RDGN
39	-J2:fuel	-P1:J21	1.5 (mm <sup>2</sup> )	GY
46	-B5	-J2:t-2	1 (mm <sup>2</sup> )	BUGN
47	-B1	-J2:t-1	1 (mm <sup>2</sup> )	BU
48	-B3	-J2:oil	1 (mm <sup>2</sup> )	VT
49	-P1:J7	-P1:J18	1.5 (mm <sup>2</sup> )	BK
54	-G3	-S2	35 (mm <sup>2</sup> )	RD
55	-P1:J24	-J3:F	1.5 (mm <sup>2</sup> )	RD
L1-1	-J2:AC1	-X4:2	10 (mm <sup>2</sup> )	BK
L1-1	-Q1:1	-G1:L1	16 (mm <sup>2</sup> )	BK
L1-2	-J2:AC2	-X4:3	10 (mm <sup>2</sup> )	BK
L2-1	-Q1:3	-G1:L2	16 (mm <sup>2</sup> )	RD
N-1	-J2:AC2	-X4:1	10 (mm <sup>2</sup> )	BK
N-1	-X4:1	-J2:AC1	10 (mm <sup>2</sup> )	BK
N-1	-G1:N	-X1-3	16 (mm <sup>2</sup> )	WH
PE-1	-X1-4	-G1:PE	16 (mm <sup>2</sup> )	GNYE
Z1	-G1:RD	-J4:Aux +	1.5 (mm <sup>2</sup> )	RD
Z2	-G1:RD	-J4:Aux-	1.5 (mm <sup>2</sup> )	RD

### 3.2.1 Lay out control wiring M-SQ PRO 15 SPLIT PHASE Kubota

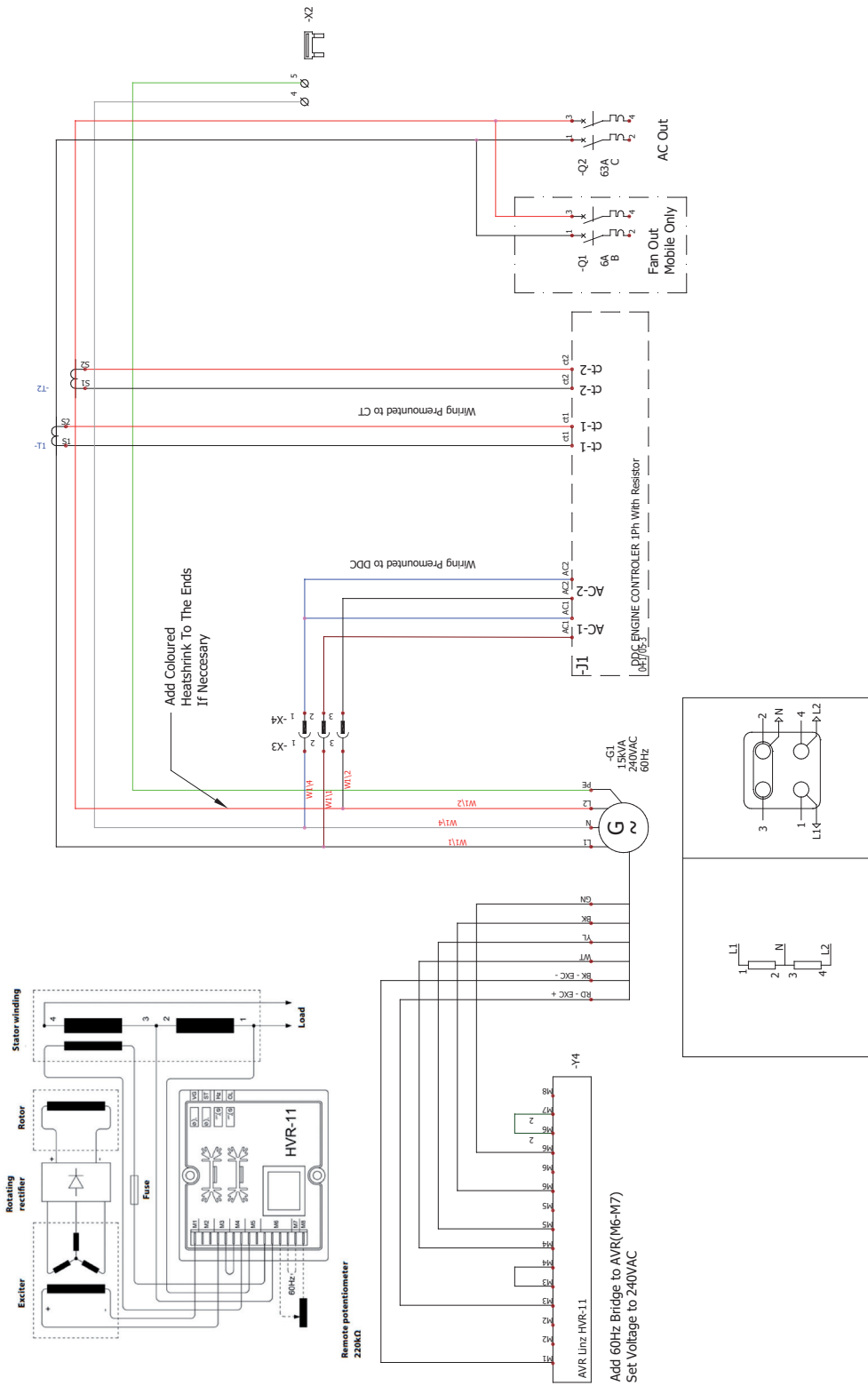

3.2.2 Lay out control wiring M-SQ PRO 15 SPLIT PHASE Kubota

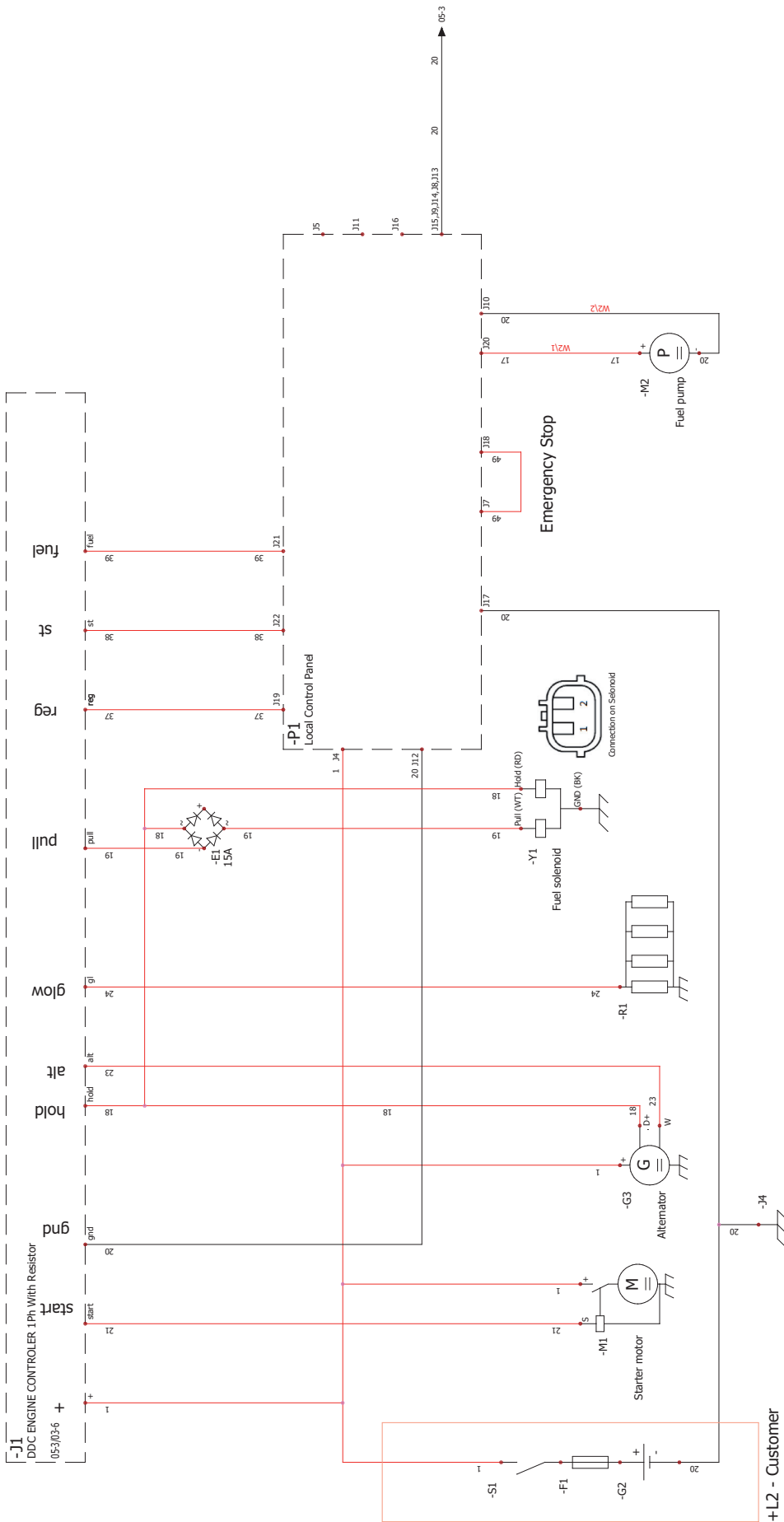



3.2.3 Lay out control wiring M-SQ PRO 15 SPLIT PHASE Kubota

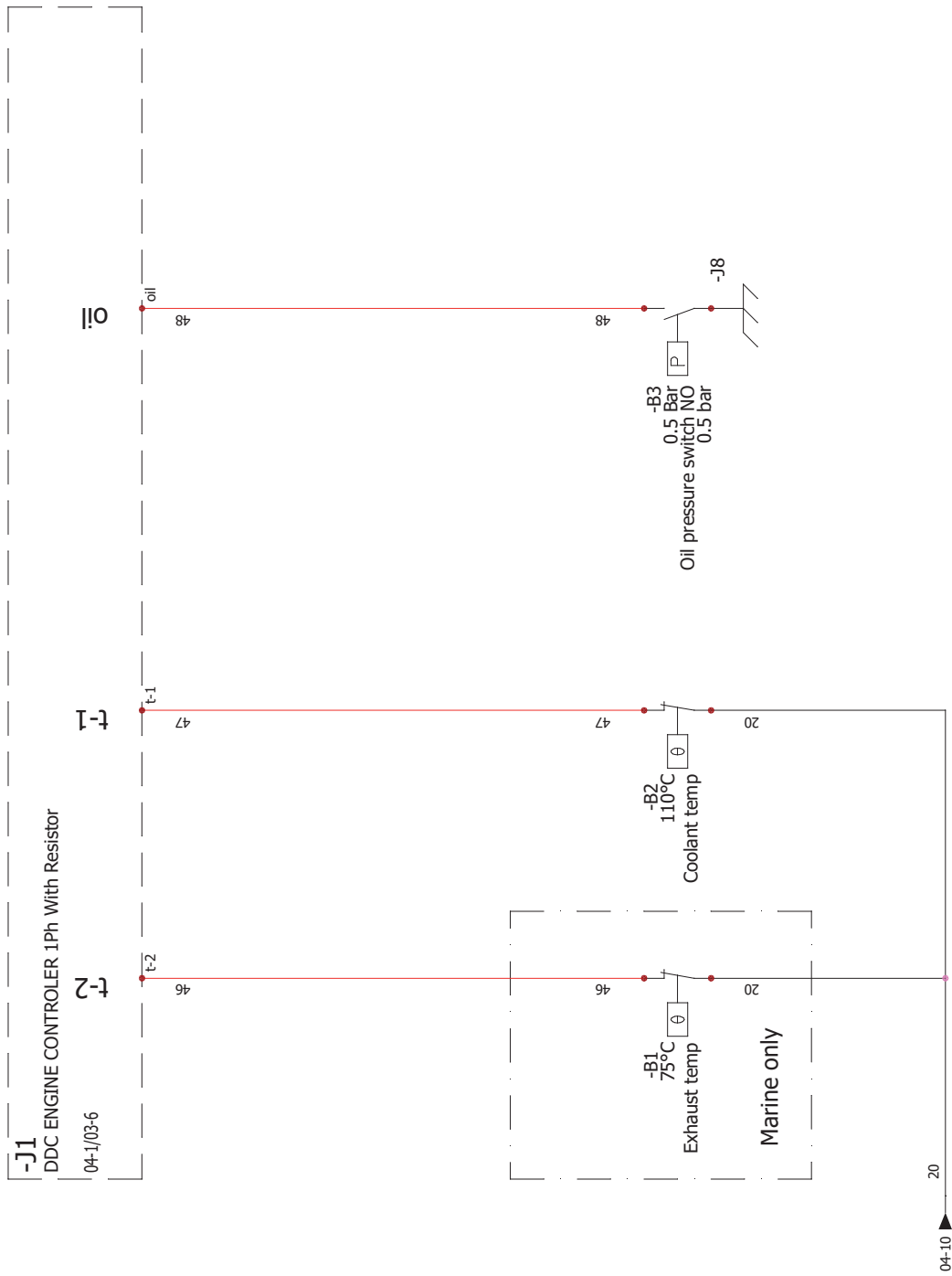
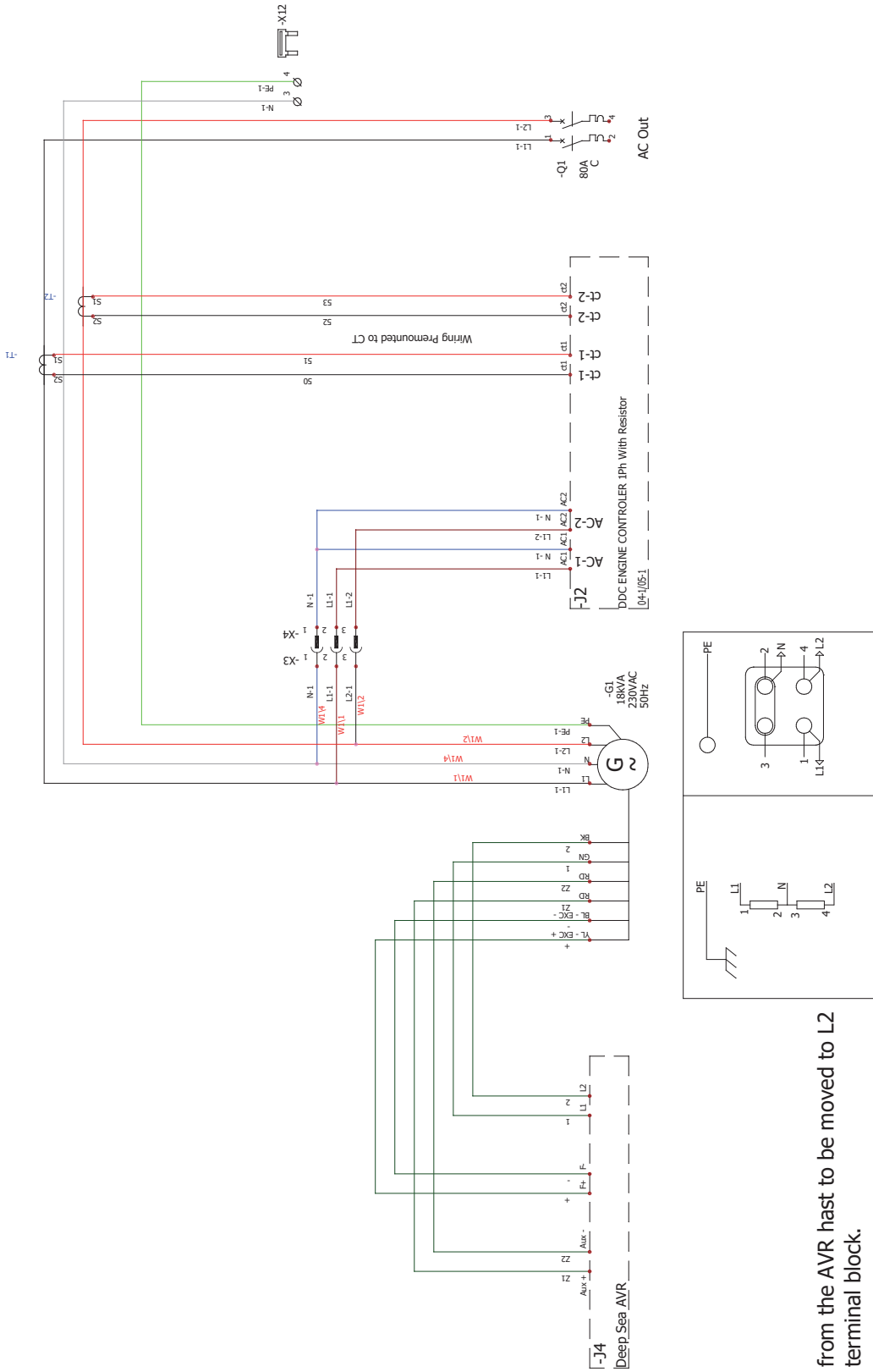

Figure 18: Terminal modes

### 3.2.4 Lay out control wiring M-SQ PRO 18 SPLIT PHASE Kubota



**Note:** Wire 2 from the AVR has to be moved to L2 on the terminal block.

3.2.5 Lay out control wiring M-SQ PRO 18 SPLIT PHASE Kubota

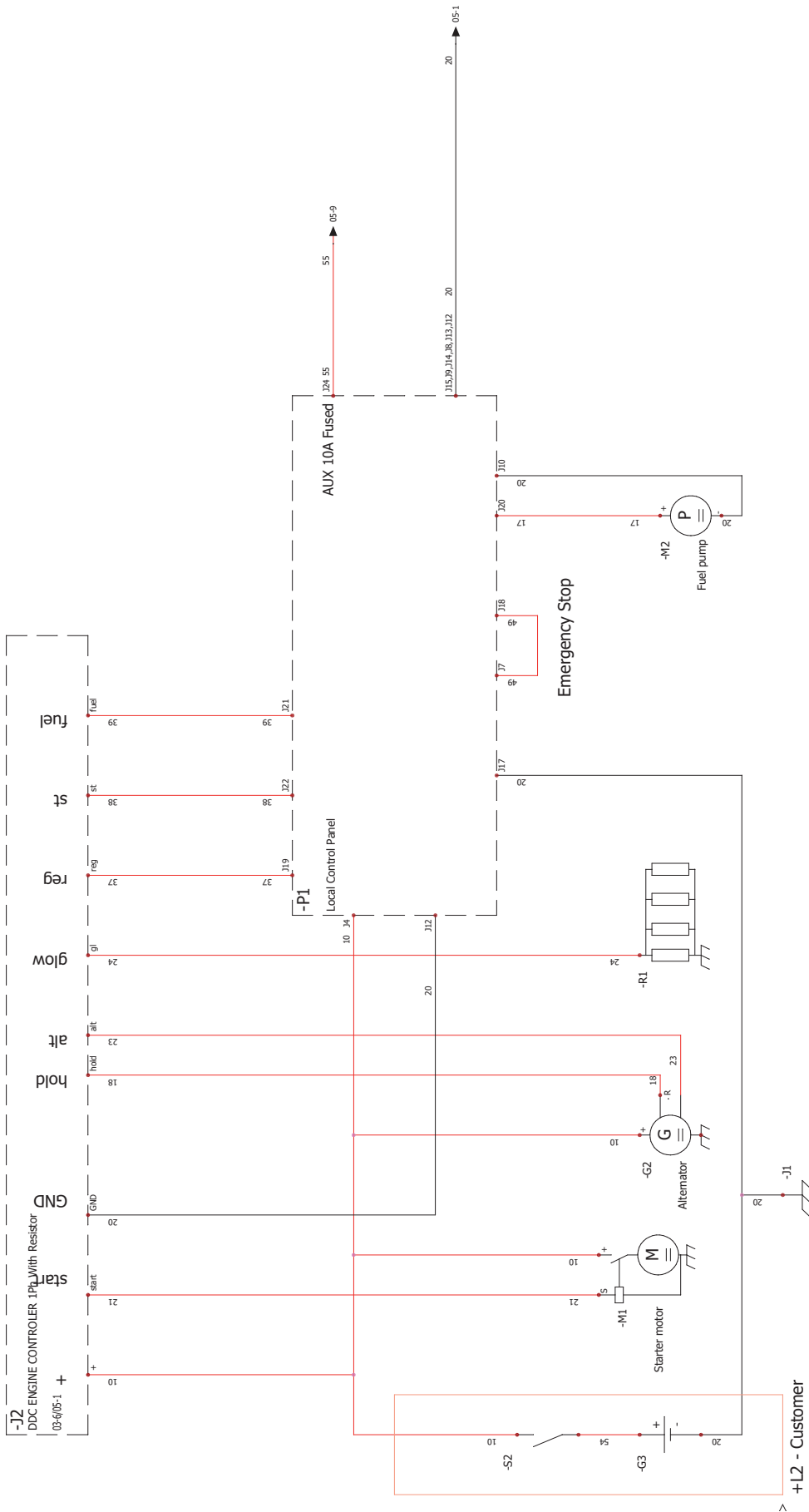

3.2.6 Lay out control wiring M-SQ PRO 18 SPLIT PHASE Kubota

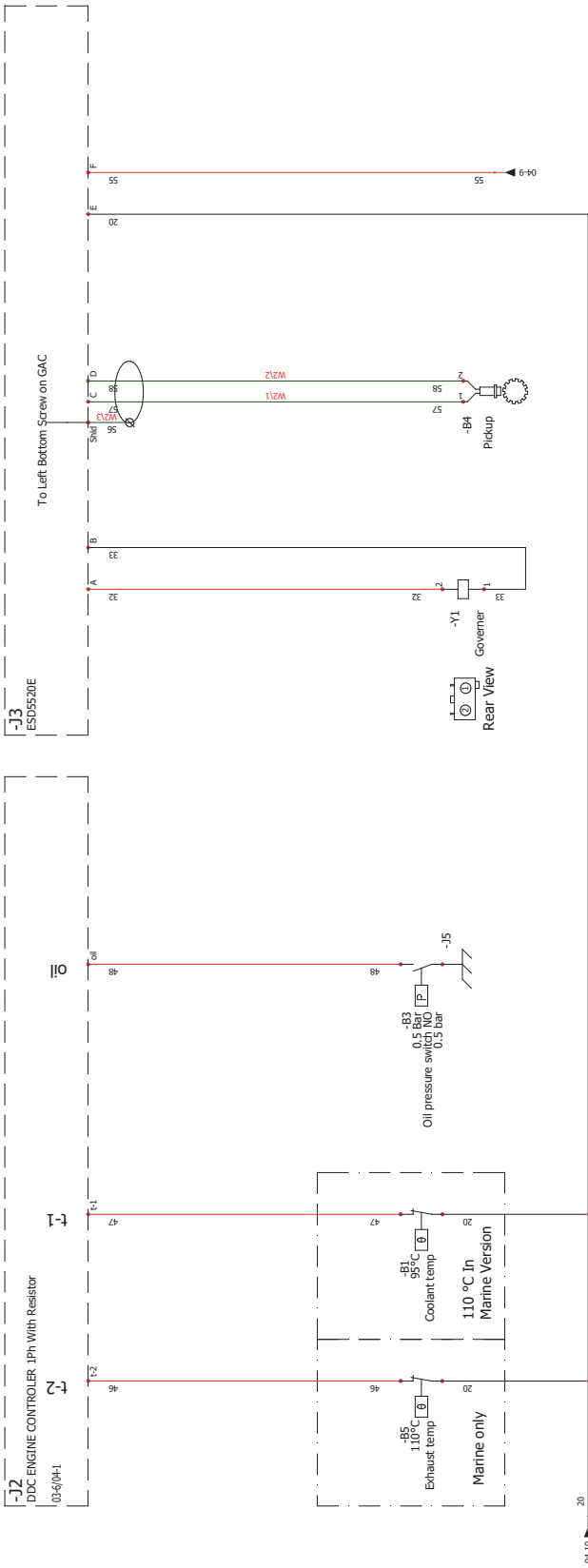

### 3.3 WhisperPower remote panel

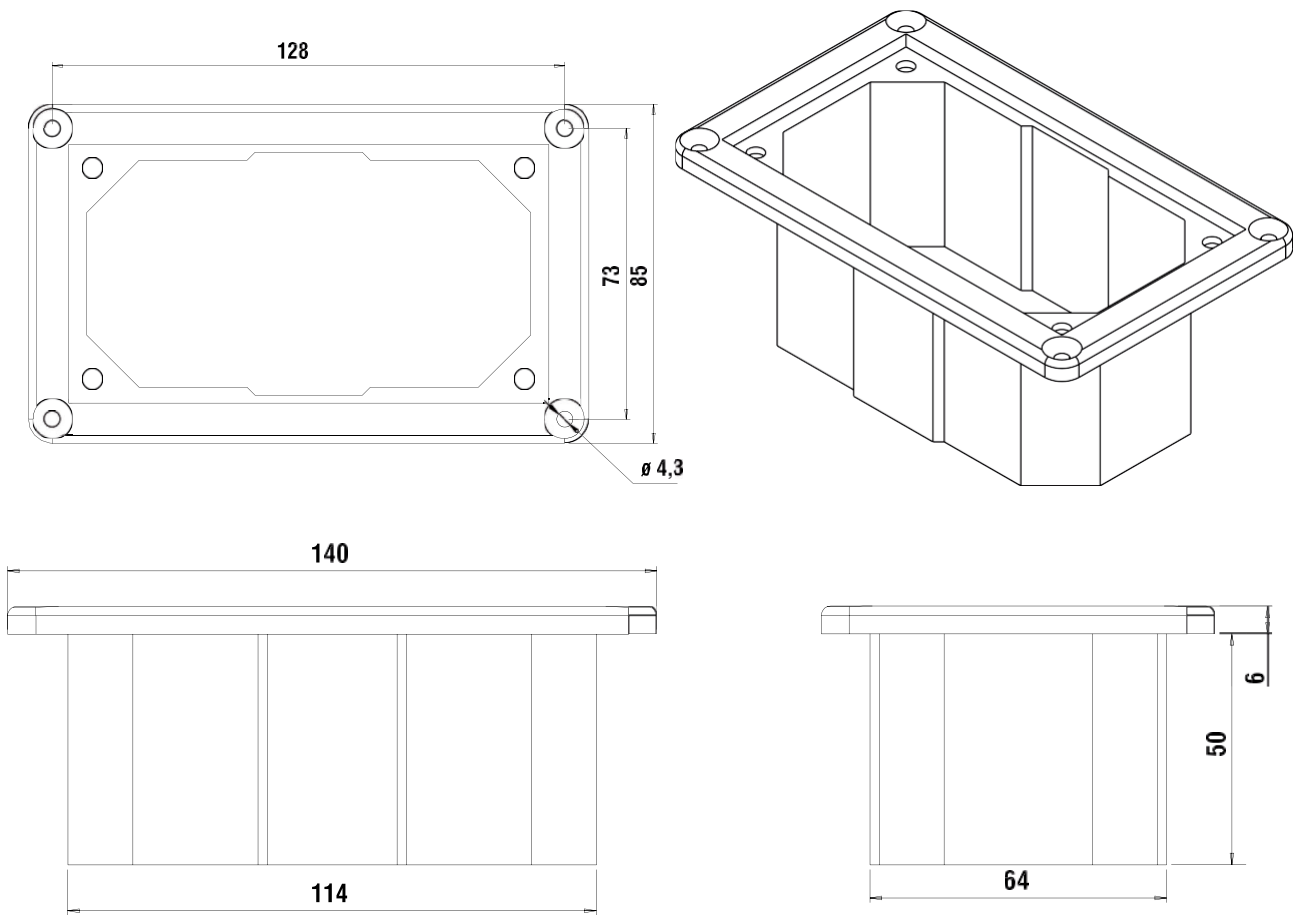

Fig. 16: WhisperPower remote panel

The remote panel comes in a carton that can be used as a template to drill the mounting hole.

### 3.4 M-SQ 15 dimensions and footprint

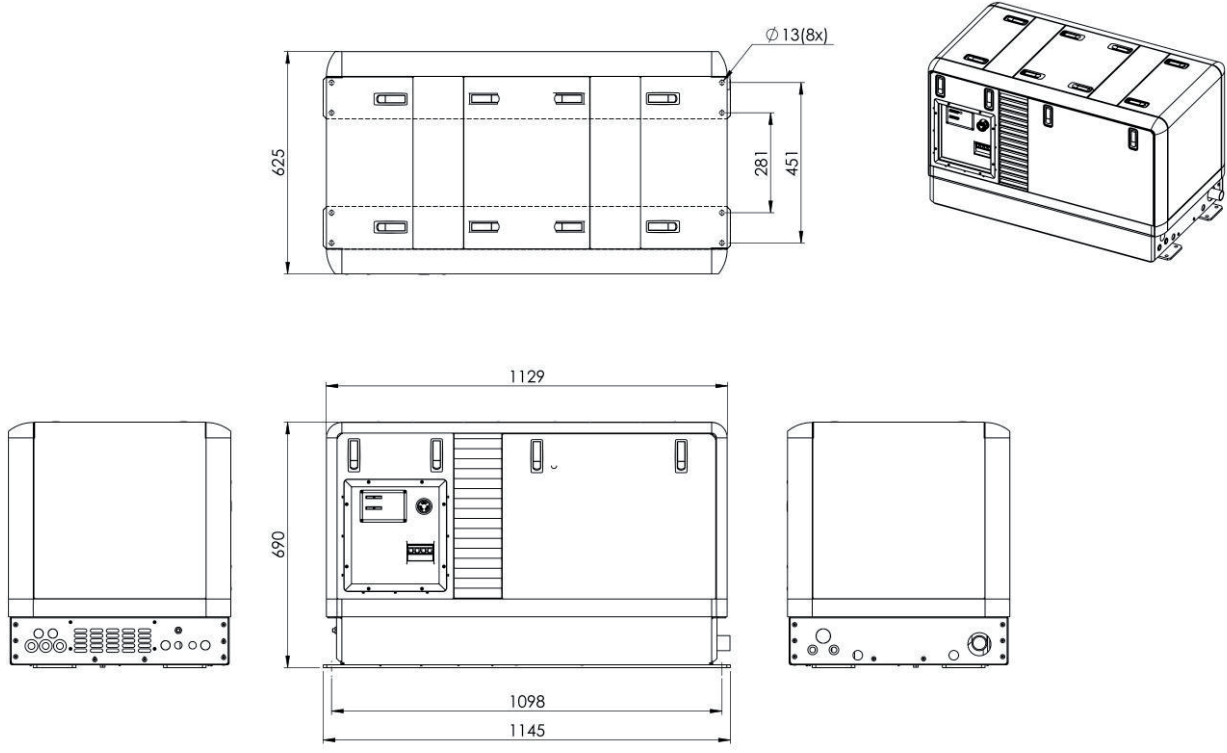

Fig. 17: Outer dimensions (mm) M-SQ- PRO 15

M-SQ- PRO 15	
CONNECTIONS	BOX DIMENSIONS
• Exhaust: 50 mm	• Length: 1145 mm
• Fuel hose: 5/16" (8 mm)	• Width: 625 mm
• Radiator engine: 3/4" (20 mm)	• Height: 690 mm
• Battery +: AWG 2 (25 mm <sup>2</sup> )	• Weight: 410 kg
• Battery -: AWG 2 (25 mm <sup>2</sup> )	

**POWER CABLES ISO 13297 annex A**

- 3 x 10 mm<sup>2</sup> or 5 x 4 mm<sup>2</sup> (not included)

**REMOTE CONTROL:**

- 15-meter 8 wire communication cable (included)

### 3.5 M-SQ 18 dimensions and footprint

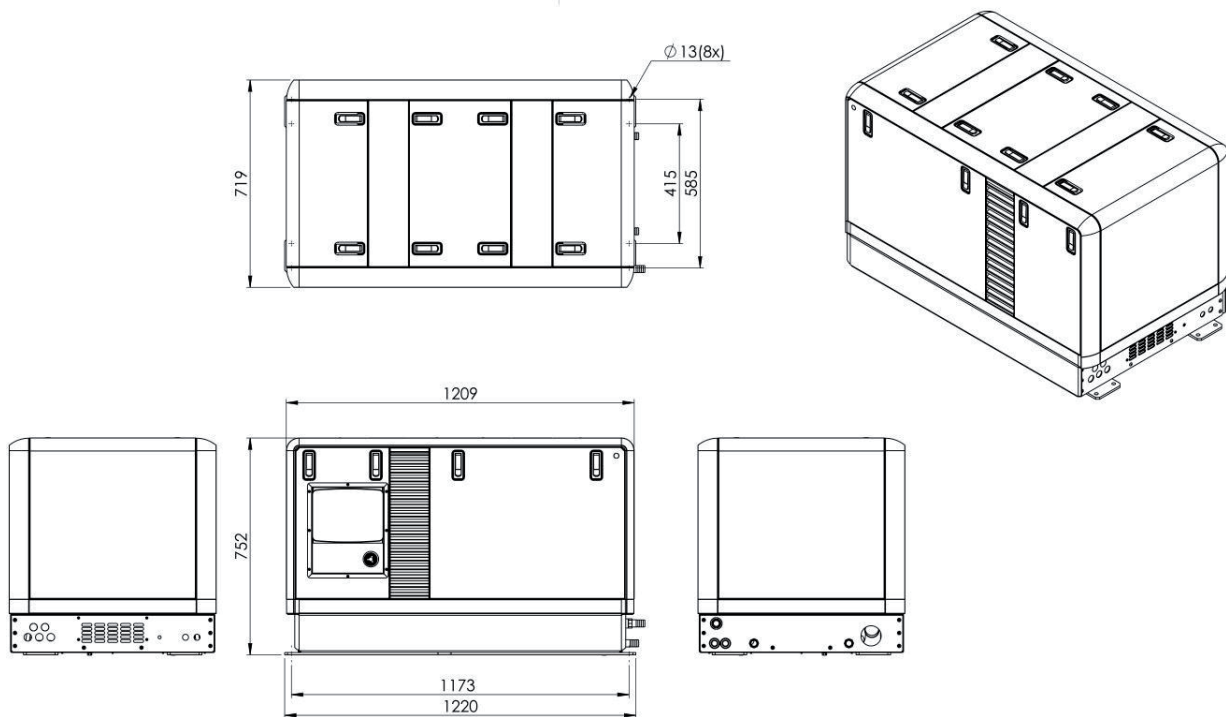

Fig. 18: Outer dimensions (mm) M-SQ- PRO 18

M-SQ- PRO 18	
<b>CONNECTIONS</b>	<b>BOX DIMENSIONS</b>
<ul style="list-style-type: none"> <li>• Exhaust: 50 mm</li> <li>• Fuel hose: 5/16" (8 mm)</li> <li>• Radiator engine: 3/4" (20 mm)</li> <li>• Battery +: 35 mm<sup>2</sup></li> <li>• Battery -: 35 mm<sup>2</sup></li> </ul>	<ul style="list-style-type: none"> <li>• Length: 1220 mm</li> <li>• Width: 719 mm</li> <li>• Height: 754 mm</li> <li>• Weight: 510 kg</li> </ul>

**POWER CABLES ISO 13297 annex A**

- 3 x 10 mm<sup>2</sup> (not included)

**REMOTE CONTROL:**

- 15-meter 8 wire communication cable (included)



Enjoy Green Energy

**WhisperPower BV**

Kelvinlaan 82,  
9207 JB Drachten  
The Netherlands

[www.whisperpower.com](http://www.whisperpower.com)  
[sales@whisperpower.com](mailto:sales@whisperpower.com)